

## REF. 744

### 3 PIECES STAINLESS STEEL BALL VALVE FEMALE NPT INITIAL RANGE

3 pieces stainless steel ball valve with full bore for Chemical industries, petrochemical industries, hydraulic installation, heating, water distribution and compressed air.  
PTFE packing and gasket, PTFE filled with 15% glass seat.  
Removable central part for an easy maintenance.



**NEW**



**Size :** DN1/4" to DN4"  
**Connection :** Female NPT  
**Min Temperature :** -20°C  
**Max Temperature :** +180°C  
**Max Pressure :** 63 bars (up to DN3/4")  
**Specifications :** 3 pieces type  
PTFE filled with 15% glass seat  
Anti blow-out stem  
Full bore

**Materials :** Stainless Steel ASTM A351 CF8M

# REF. 744

## 3 PIECES STAINLESS STEEL BALL VALVE FEMALE NPT INITIAL RANGE

**SPECIFICATIONS :**

- Full bore
- Anti blow-out stem
- PTFE packing
- Locking device
- Stem extension in AISI 304 ( option )

**USE :**

- Chemical and pharmaceutical industries, petrochemical industries, hydraulic installation, compressed air
- Min and max Temperature Ts : -20°C to + 180°C
- Max Pressure Ps : 63 bars up to DN20, 40 bars from DN25 to 50, 25 bars from DN65 to 80 and 20 bars for DN100 (see graph under)
- Compressed air : 10 bars max
- Do not use with steam

**PRESSURE / TEMPERATURE GRAPH ( STEAM AND COMPRESSED AIR EXCLUDED ) :**

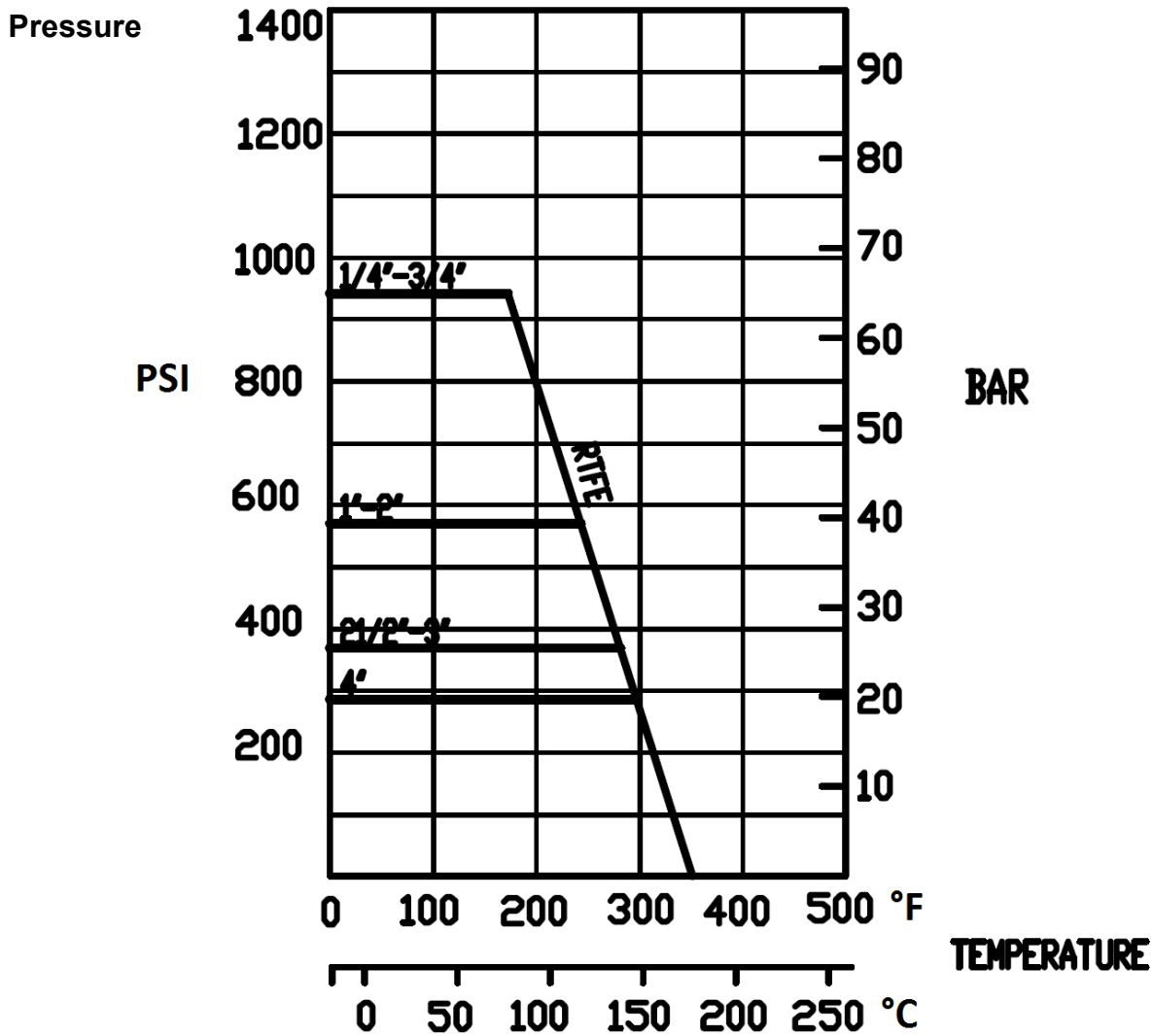

## REF. 744

### 3 PIECES STAINLESS STEEL BALL VALVE FEMALE NPT INITIAL RANGE

**TORQUE VALUES ( In Nm without safety coefficient ) :**

DN	1/4"	3/8"	1/2"	3/4"	1"	1"1/4	1"1/2	2"	2"1/2	3"	4"
Torque (Nm)	2	2	2.5	3.5	6	7	12	16	40	50	70

**BOLT TIGHTENING TABLE ( in Nm ) :**

DN	1/4"	3/8"	1/2"	3/4"	1"	1"1/4	1"1/2	2"	2"1/2	3"	4"
Torque (Nm)	4	4	8	8	10	13	20	20	35	45	65

**FLOW COEFFICIENT Kvs ( M3 / h ) :**

DN	1/4"	3/8"	1/2"	3/4"	1"	1"1/4	1"1/2	2"	2"1/2	3"	4"
Kvs ( m3/h )	5.2	5.2	20.7	30.2	40.6	70	90.8	208.4	275.9	501.6	865

**RANGE :**



- Stainless steel 3 pieces ball valve Initial Range Female NPT **Ref. 744** from DN1/4" to DN4"



- AISI 304 stem extension **Ref.9810611-9810614** from DN8 to DN50



- Blue handle cover **Ref. 9830584-9830588** from DN 1/2" to DN 4"

**CONNECTION :**

- Female / female threaded NPT

# REF. 744

## 3 PIECES STAINLESS STEEL BALL VALVE FEMALE NPT INITIAL RANGE

**MATERIALS :**

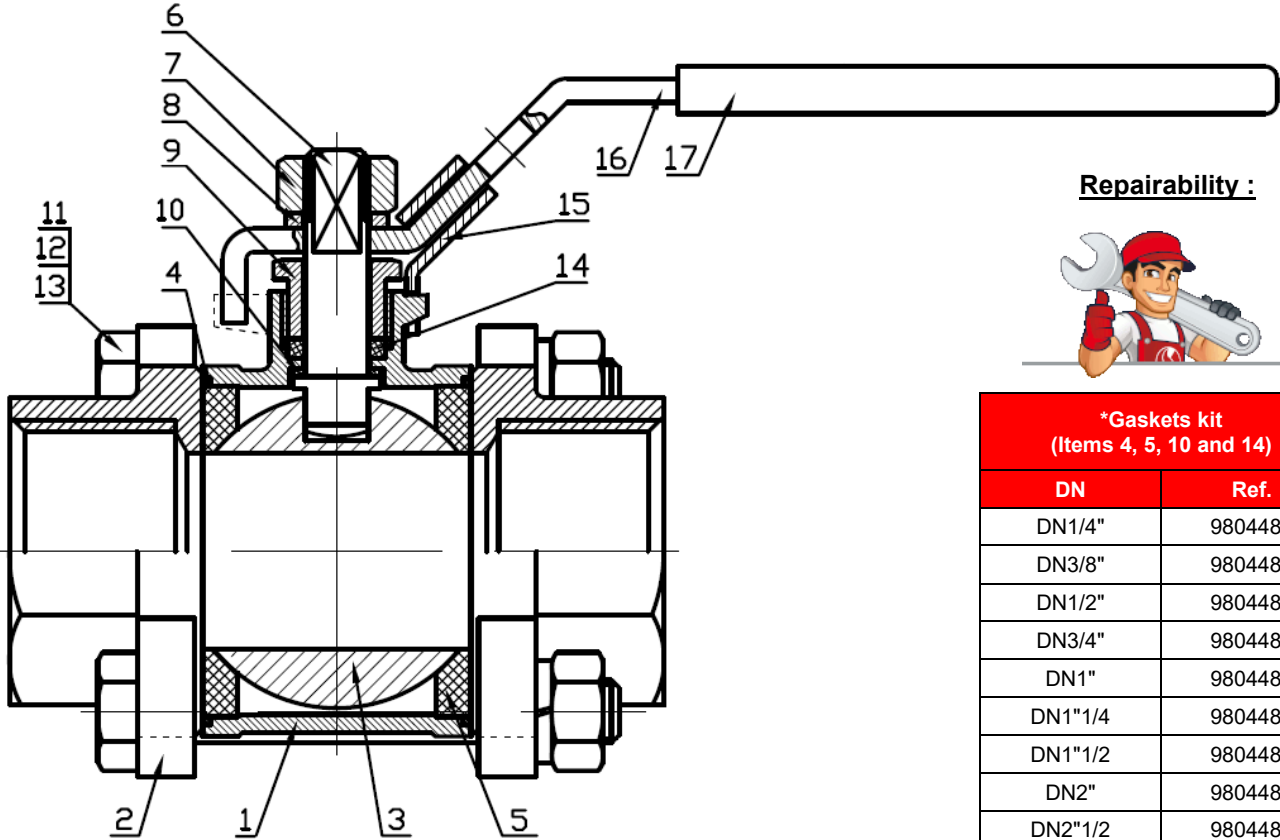

**Repairability :**



*Gaskets kit (Items 4, 5, 10 and 14)	
DN	Ref.
DN1/4"	9804480
DN3/8"	9804481
DN1/2"	9804482
DN3/4"	9804483
DN1"	9804484
DN1"1/4	9804485
DN1"1/2	9804486
DN2"	9804487
DN2"1/2	9804488
DN3"	9804489
DN4"	9804490

Item	Designation	Materials
1	Body	ASTM A351 CF8M
2	Ends	
3	Ball	AISI 316
4*	Body gasket	PTFE
5*	Seat	PTFE filled with 15% glass fiber
6	Stem	AISI 316
7	Packing nut	AISI 304
8	Handle washer	
9	Packing gland	
10*	Thrust washer	PTFE
11	Stud	AISI 304
12	Stud washer	
13	Stud nut	
14*	Packing	PTFE
15	Locking device	AISI 304
16	Handle	
17	Handle cover	

(\* : Included in gaskets kit)

# REF. 744

## 3 PIECES STAINLESS STEEL BALL VALVE FEMALE NPT INITIAL RANGE

**SIZE:**

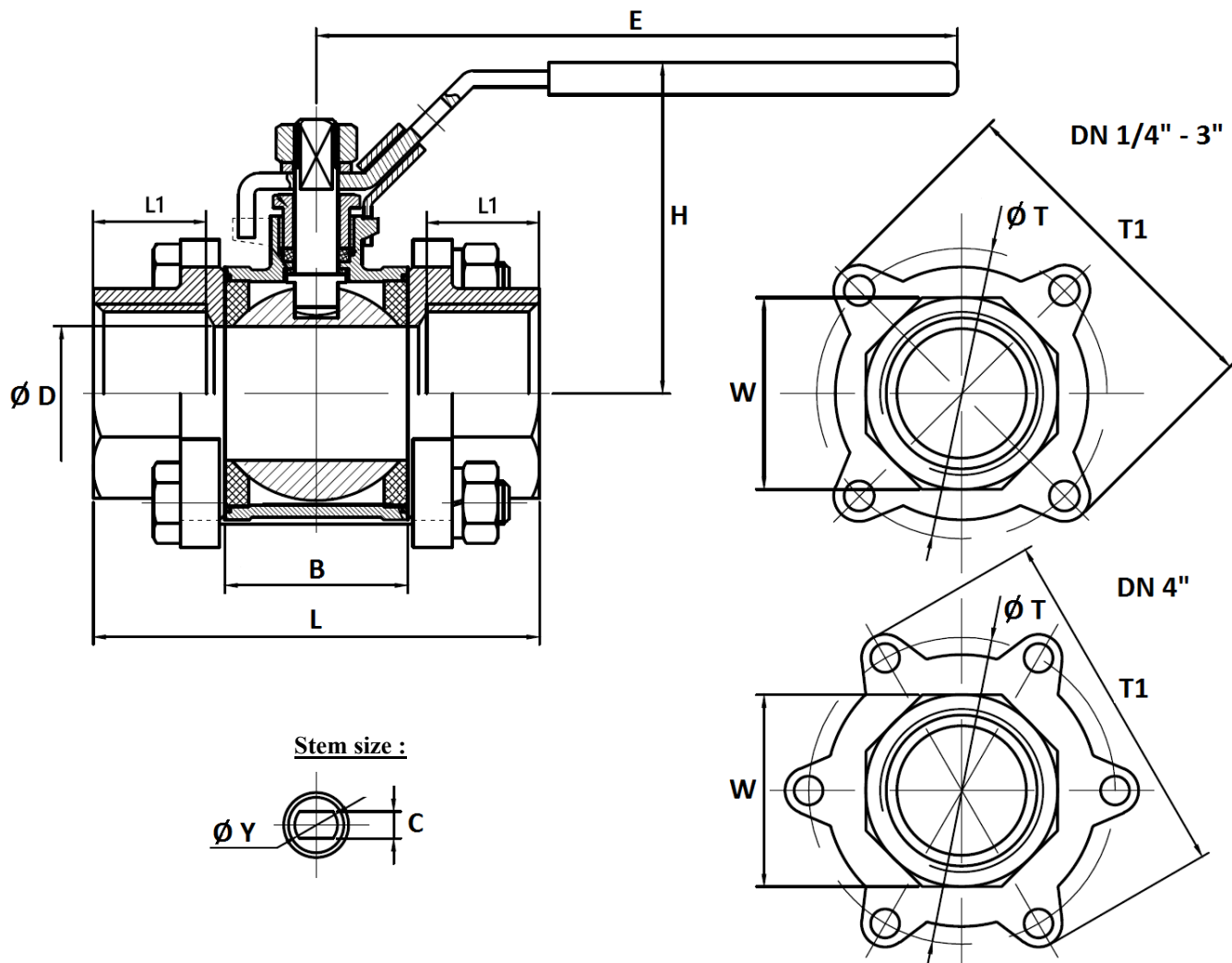

Stem size :

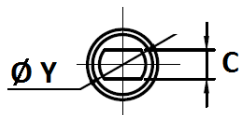

DN	1/4"	3/8"	1/2"	3/4"	1"	1 1/4"	1 1/2"	2"	2 1/2"	3"	4"
Ø D	11.6	12.5	15	20	25	32	38	50	64	76	100
L	59	59	63.3	70.6	82	97	109	124.6	162	175	216
L1	13.5		15.5	16	19	21.5	23.5	25.5	33.5	35	42
B	21.1	21.1	23.3	28.6	34	44	51	63	84.3	94.7	119.2
E	103	103	126	126	162	162	193	193	230	230	320
H	49	49	57	62	72	78	91	102	122	132	177
Ø Y	M8	M8	M8	M8	M10	M10	M12	M12	M14	M14	M20
C	5	5	5	5	6.5	6.5	8.5	8.5	9.8	9.8	16
Ø T	38.5	38.5	43	51.5	58	70	81.5	101	136	157	195.5
T1	51	51	57.5	66	74.5	86.5	100.5	121.5	161	185	226.5
W	18	21	26	32	39	48	55	67	83	99	127
Weight (Kg)	0.3	0.3	0.48	0.63	0.93	1.38	2.03	3.28	7.11	10.45	21.24
Ref.	744002	744003	744004	744005	744006	744007	744008	744009	744010	744011	744012

# REF. 744

## 3 PIECES STAINLESS STEEL BALL VALVE FEMALE NPT INITIAL RANGE

STEM EXTENSION ( in mm ) :

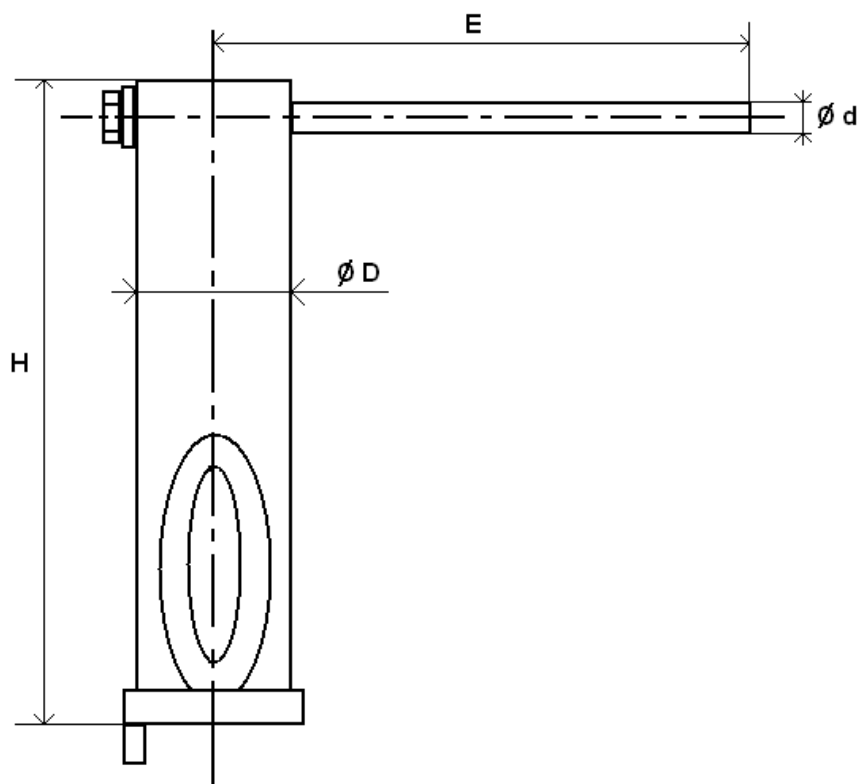

DN	1/4"	3/8"	1/2"	3/4"	1"	1"1/4"	1"1/2"	2"
H	126		126.3		126.3		128	
E	124		124		157.8		188.5	
Ø D	28		28		32		36.5	
Ø d	12		12		14		14	
Weight (in Kg)	0.33		0.34		0.48		0.62	
Ref.	9810611		9810612		9810613		9810614	

## REF. 744

### 3 PIECES STAINLESS STEEL BALL VALVE FEMALE NPT INITIAL RANGE

**STANDARDS :**

- Manufacturer certified ISO 9001 : 2015
- DIRECTIVE 2014/68/EU : For liquids and gas of Group 1
  - DN1/4"-1" : Article 4, §3 (SEP), no CE marking
  - DN1"1/4-4" : Risk Category II, CE0038 or CE0343 marking
- Designing according to EN 12516-2
- Certificate 3.1 on request
- Pressure tests according to API 598, table 6
- Threaded NPT ends according to ANSI B1.20.1

**ADVICE :** Our opinion and our advice are not guaranteed and shall not be liable for the consequences of damages. The customer must check the right choice of the products with the real service conditions.