

## REF. 742

### 3 PIECES BALL VALVE WITH ISO MOUNTING PAD PN 63 INITIAL RANGE SW

3 pieces stainless steel ball valve with full bore for Chemical industries, petrochemical industries, hydraulic installation, heating, water distribution, compressed air.

PTFE packing, FKM O ring gasket on stem and PTFE filled with 15% glass seat.

Compatible with explosive atmosphere, ATEX Zone 1&21 and Zone 2&22 thanks to the antistatic device.

Thanks to the ISO 5211 plate, an actuator can be installed on the valve.



**Certificate**  
**3.1**



**LRQA**  
PED/2014/68/UE



**Size :** DN15 to DN50

**Connection :** SW

**Min Temperature :** -20°C

**Max Temperature :** +180°C

**Max Pressure :** 63 Bars up to DN20

**Specifications :** ISO 5211 mounting pad

PTFE filled with 15% glass seat

Anti blow-out stem, full bore

ATEX

**Materials :** Stainless steel ASTM A351 CF8M

## REF. 742

### 3 PIECES BALL VALVE WITH ISO MOUNTING PAD PN 63 INITIAL RANGE SW

**SPECIFICATIONS :**

- Full bore
- Anti blow-out stem
- PTFE packing
- ISO 5211 direct mounting pad
- Double antistatic device (between stem-body and stem-ball)
- Atex
- Locking device

**USE :**

- Chemical industries, petrochemical industries, hydraulic installation, heating, water distribution, compressed air
- Min and max Temperature Ts : -20°C to + 180°C
- Max Pressure Ps : 63 bars up to DN20, 40 bars from DN25 to DN50 (see graph under)

**PRESSURE / TEMPERATURE GRAPH ( STEAM AND COMPRESSED AIR EXCLUDED ) :**

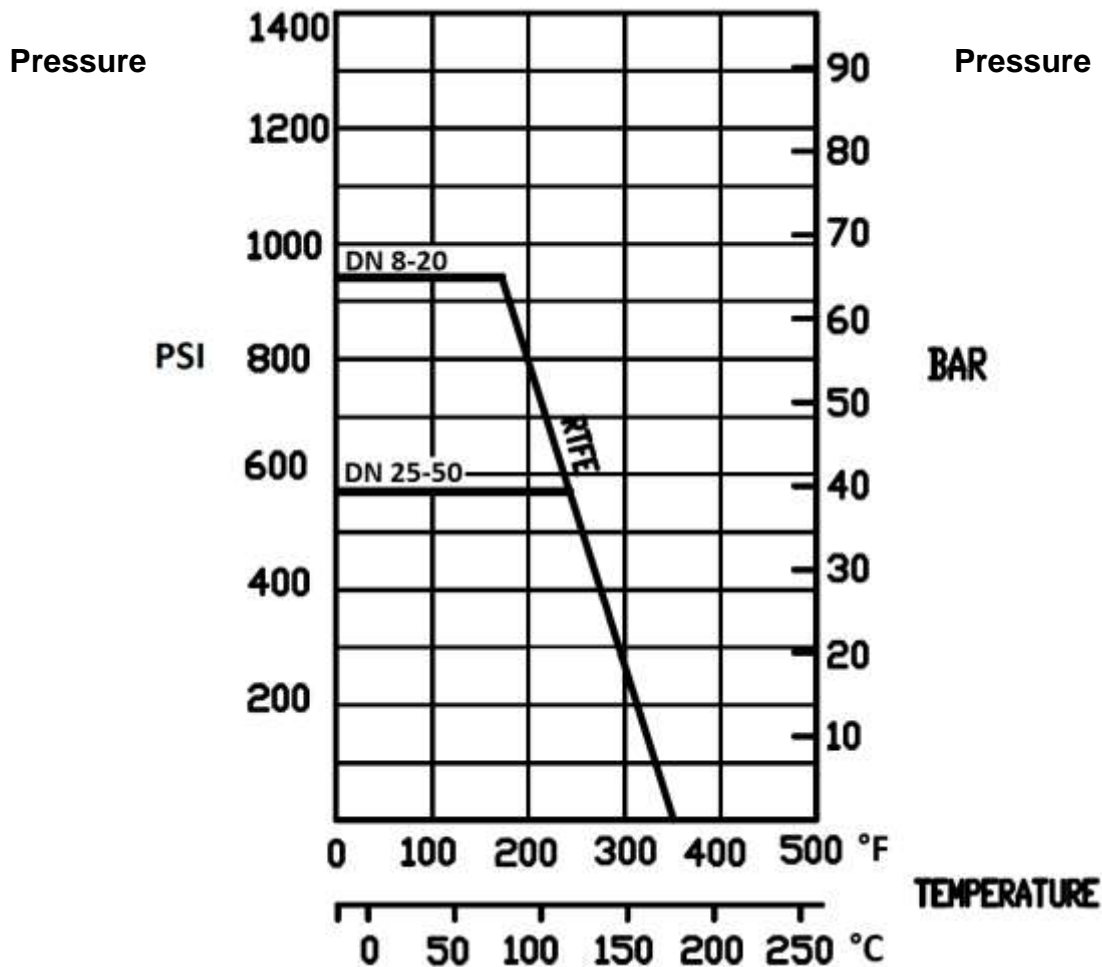



## REF. 742

### 3 PIECES BALL VALVE WITH ISO MOUNTING PAD PN 63 INITIAL RANGE SW

**TORQUE VALUES ( in Nm without safety coefficient ) :**

DN	15	20	25	32	40	50
Torque (Nm)	2.5	3.5	6	7	12	16

**BOLT TIGHTENING TABLE ( in Nm):**

DN	15	20	25	32	40	50
Torque (Nm)	8	8	10	13	20	20

**FLOW COEFFICIENT Kvs ( m3 / h ) :**

DN	15	20	25	32	40	50
Kvs ( m3/h )	20.7	30.2	40.6	70	90.8	208.4

**RANGE :**

- 3 pieces ball valve with ISO mounting pad Socket Welding ends **Ref. 742 from DN15 to DN50.**

# REF. 742

## 3 PIECES BALL VALVE WITH ISO MOUNTING PAD PN 63 INITIAL RANGE SW

**MATERIALS :**

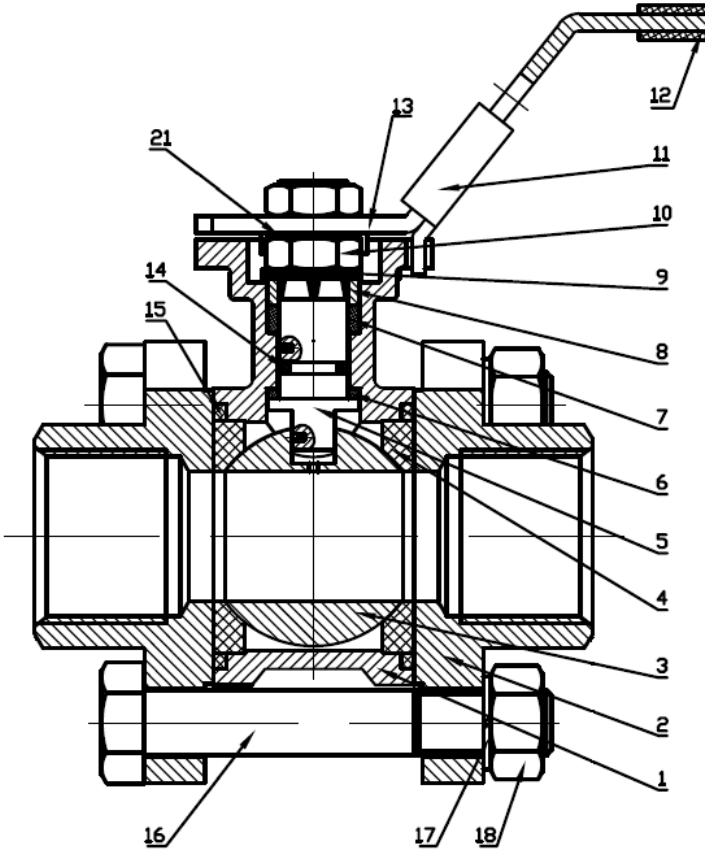

Item	Designation	Materials
1	Body	ASTM A351 CF8M
2	End cap	
3	Ball	AISI 316
4*	Seat	PTFE + 15% glass
5	Stem	AISI 316
6*	Stem seal	PTFE
7*	Packing	
8	Thrust washer	AISI 304
9	Elastic ring	
10	Packing nut	
11	Locking device	
12	Handle cover	Plastic
13	Handle	AISI 304
14	O Ring	FKM
15*	Body gasket	PTFE
16	Stud	AISI 304
17	Washer	
18	Nut	
21	Washer	

(\* : included in gaskets kit)

**Repairability :**



*Gaskets Kit (Items 4, 6, 7 and 15)	
DN	Ref.
DN15	9804502
DN20	9804503
DN25	9804504
DN32	9804505
DN40	9804506
DN50	9804507

# REF. 742

## 3 PIECES BALL VALVE WITH ISO MOUNTING PAD PN 63 INITIAL RANGE SW

**SIZE ( en mm ):**

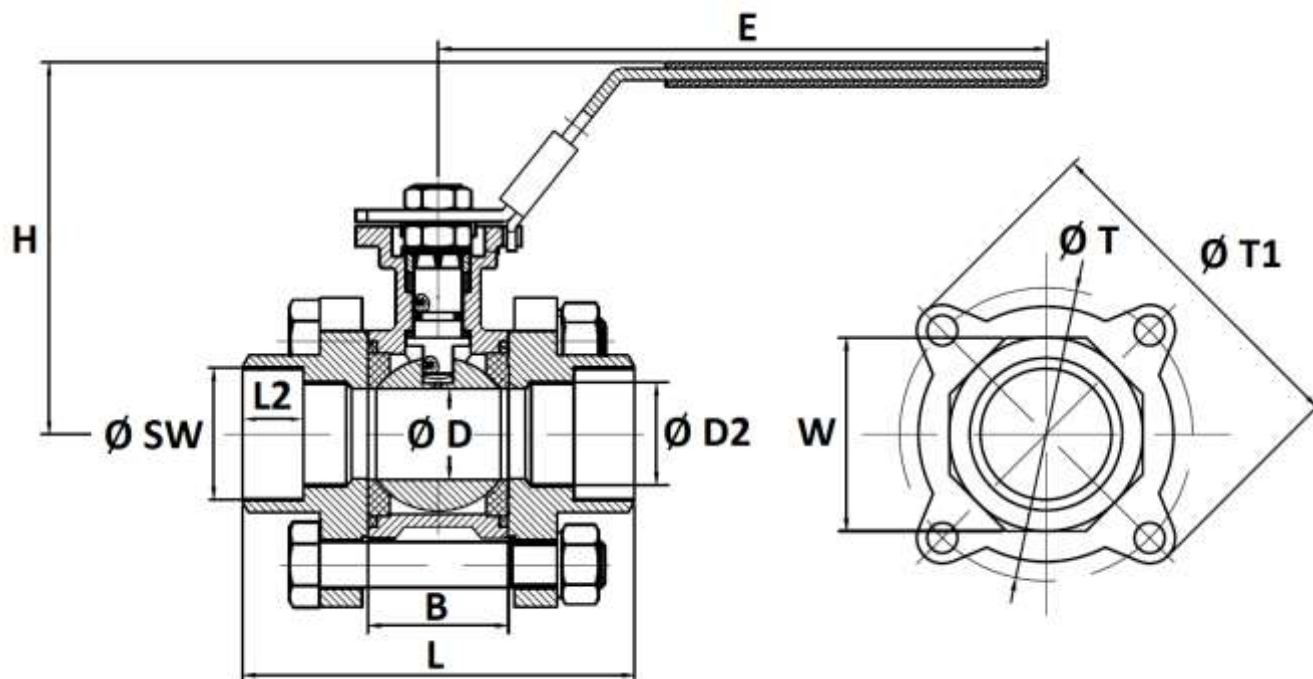

DN	15	20	25	32	40	50
Ø D	15	20	25	32	38	50
L	66	70.6	82	97	109	124.6
B	26	28.6	34	44	51	62.8
L2	11	14	18	18	19	21
E	141	141	162	162	188	188
H	75	81	93	98	109	124
Ø T	47.5	51.5	58	70	81.5	101
T1	62	66	74.5	86.5	100.5	121.5
W	26	32	39	48	55	67
Ø SW	21.9	27.4	34.2	42.8	48.8	61.1
Ø D2	18	23.5	29.5	38.5	44.5	56
Weight (in Kg)	0.62	0.6	1.09	1.55	2.4	3.59
Ref.	742015	742020	742025	742032	742040	742050

# REF. 742

## 3 PIECES BALL VALVE WITH ISO MOUNTING PAD PN 63 INITIAL RANGE SW

ISO MOUNTING PAD AND STEM SIZE ( in mm ) :

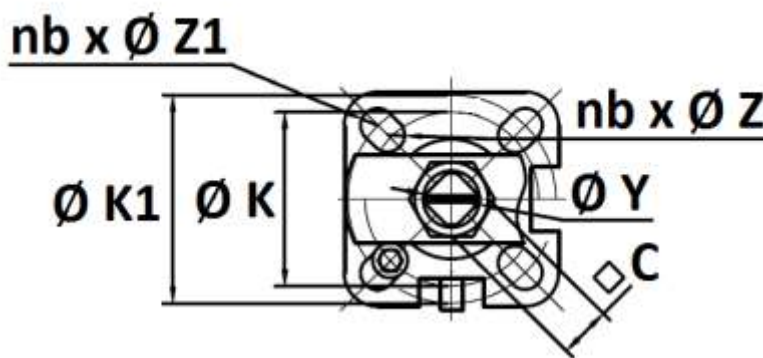
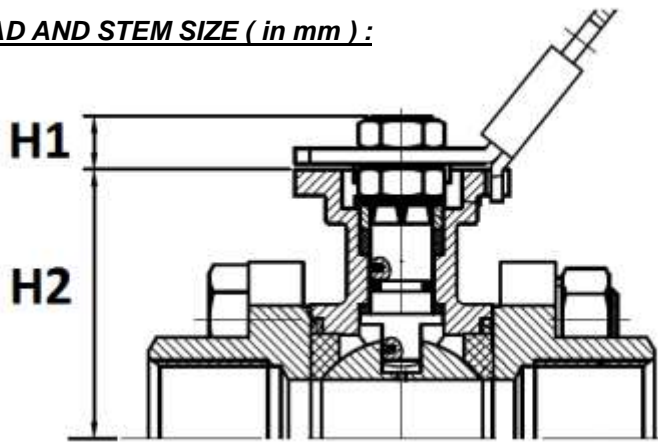

DN	15	20	25	32	40	50
C	9		11		14	
Ø Y	M12x1.5		M14x1.5		M18x1.5	
H1	9		11		15	
H2	42	48	55	60	70	85
Ø K	36		42		50	
ISO	F03		F04		F05	
nb x Ø Z	4 x 6				4 x 7	
Ø K1	42		50		70	
ISO 1	F04		F05		F07	
N x Ø Z1	4 x 6		4 x 7		4 x 9	

## REF. 742

### 3 PIECES BALL VALVE WITH ISO MOUNTING PAD PN 63 INITIAL RANGE SW

#### STANDARDS :

- Manufacturer certified ISO 9001 : 2015
- DIRECTIVE 2014/68/EU : For liquids and gas of Group 1
  - DN15-25 : Article 4, §3 (SEP), no CE marking
  - DN32-50 : Risk Category II, CE0038 or CE0343 marking
- Construction according to EN 12516-2
- Certificate 3.1 on request
- Pressure tests according to API 598
- ISO 5211 mounting pad
- ATEX Group II Category 2G IIA TX (optional marking) according to Directive 2014/34/UE

**ADVICE :** Our opinion and our advice are not guaranteed and shall not be liable for the consequences of damages. The customer must check the right choice of the products with the real service conditions.