

Lumistar Luminaire USL 05-Ex, USL 05-LED-Ex

II 2G Ex d IIC T3/T4/T6/120°C Gb
II 2D Ex tb IIIC T80/T120/T130/T195°C Db

- **For mounting on sight glass fittings:**
This Ex-type sight glass luminaire is designed for universal applications in potentially explosive environments. It is ideal for use in combined sight and light-glass arrangements, either as a single flange version or with two separate flanged ports.
- **Compact yet powerful:**
Dazzle-free illumination; for use with circular sight glass fittings to DIN 28120/DIN 28121 or similar, with screw-type sight glass fittings in compliance with DIN 11851, and in visual flow indicators.
- **Optimal design of screw-type lens ensures max. light efficiency.**
- **Application:** For illuminating the interior of tanks, hoppers, silos, agitators and other - normally closed - vessels and reactors as well as visual flow indicators in potentially **explosive environments**.
Gas: Zones 1 and 2, Dust: Zones 21 and 22.
Suitable for use in food processing industries.
- **Protection:** IP 65 and IP 67 to DIN EN 60529
- **Operating conditions:**
Independent of the internal pressure/vacuum in vessel. Under no circumstances should a sight glass luminaire be used on its own to close a vessel port or to replace the cover flange or the sight glass/luminaire assembly.
- **Lumistar luminaires of this series are approved for use in ambient temperatures of up to 60°C, depending on the lamp bulb fitted.**
- **Technical data Ex protection:**
This luminaire meets the essential safety and health requirements by complying with the regulations for
 - a) **Gas**
EN 60079-0: 2009 General Requirements
EN 60079-1: 2007 Flame-proof Enclosures 'd'
Explosion group: IIC (includes IIA und IIB)
Temperature class: T3/T4/T6/120°C (depending on wattage)
 - b) **Dust**
EN 60079-0: 2009 General Requirements
EN 60079-31: 2009 Protection by Enclosures 't'
Explosion group: IIIC (includes IIIA und IIIB)
Temperature class: T80/T120/T130/T195°C (depend. on wattage)
- **Certification:** EC Type-Examination Certificate BVS 08 ATEX E 133
II 2G Ex d IIC T3/T4/T6/120°C Gb
II 2D Ex tb IIIC T80/T120/T130/T195°C Db
- **Voltage:** Alternating/direct current, depending on lamp
- **Operating voltage:**
 - Without integrated transformer:**

12 V...	Halogen lamp	5 W or 20 W
24 V...	Halogen lamp	20 W
230 V...	LED illuminant	4 W
 - With integrated transformer; PTC-protected:**

120 V...	Halogen lamp	12 V/5 W
230 V...	Halogen lamp	12 V/5 W
- **Convenient lamp replacement thanks to optimised screw-type opening.**
- **Connecting cable:** Works-fitted cable is resin-cast in screwed cable gland for pressure-tight cable entry. Lengths: 2 m (standard), 5 m or 20 m.

CE 0158

3755.177 d
Data Sheet 07.05



Lumistar luminaire USL 05-LED-Ex

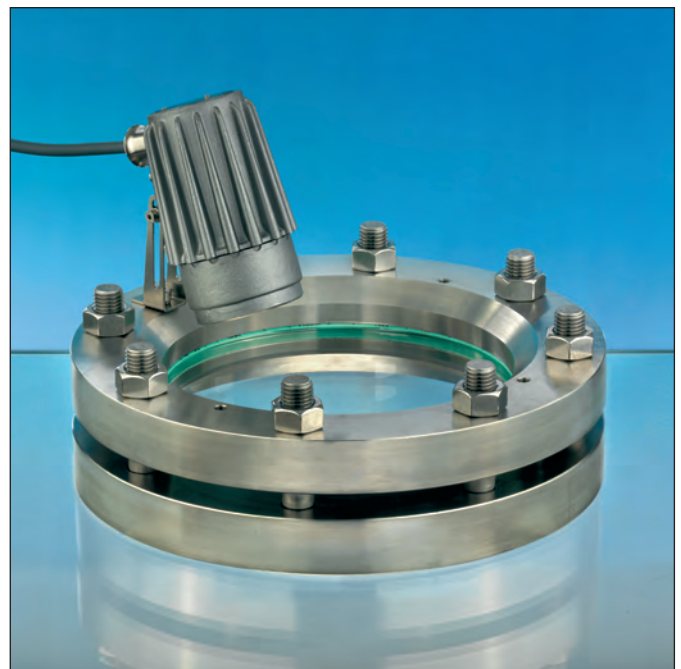

Combined light and sight glass assembly on a sight glass fitting acc. to DIN 28120; luminaire is mounted on a hinged bracket

- **Simple installation by means of special bracket.**
- **Type USL 05-Ex fits the following nominal sizes:**
 - a) Circular sight glass fittings to DIN 28120, DIN 28121 and flow indicators; for attachment to cover flange: from DN 25 up.
 - b) Screw-type sight glass fittings similar to DIN 11851; for attachment on or below the slotted nut:
 - DN 65, 80: by way of flanged adapter collar
 - DN 65, 80, 100, 125: by way of hinged bracket

• **Dimensions and electrical data for Lumistar luminaires USL 05-Ex and USL 05-LED-Ex:**

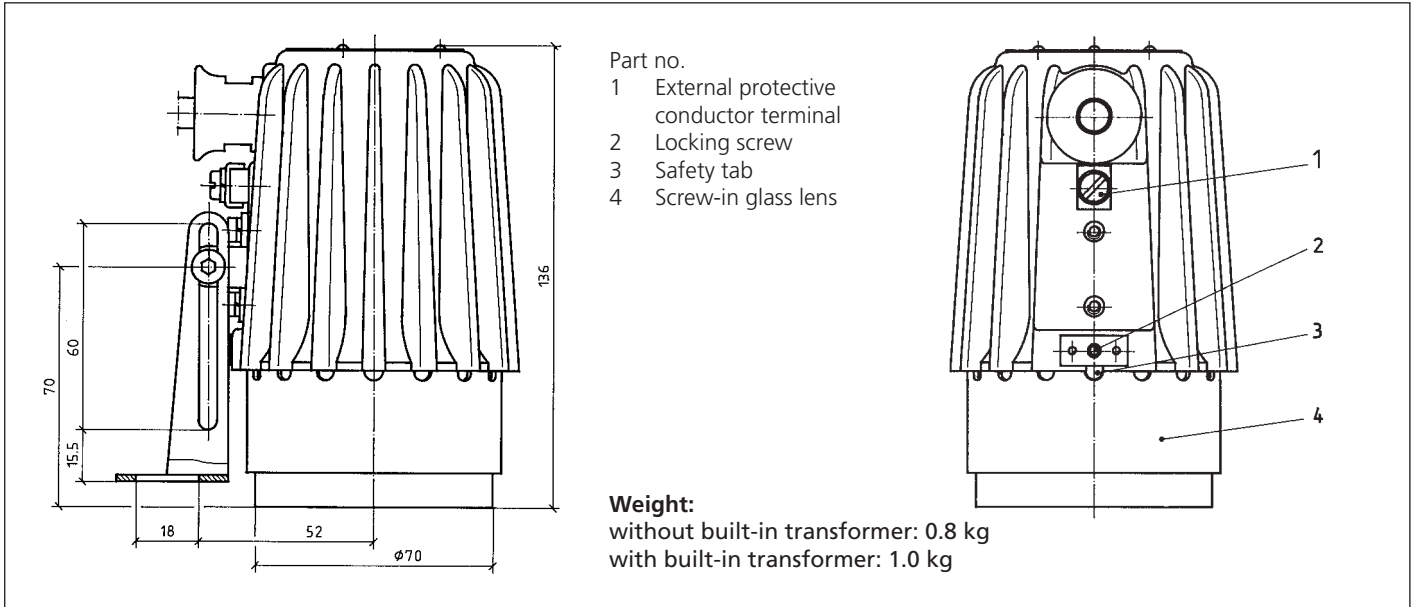

• **Components, design and materials:**

- Body of luminaire: Corrosion-resistant die-cast aluminium alloy, GK-ALSi10Mg
- Cable gland with pressure-tight resin-cast connecting cable, Sinotherm 110 H05GG-F 3G, 1.5 mm², standard cable length: 2 m
- Protective conductor terminal: Internal terminal already connected, additional external protective conductor terminal on enclosure
- Light exit: Bonded unit made of aluminium ring and glass; Viton seal
- Fastening components: See accessories

• **Connecting data: Temperature classification and electrical parameters (see also: EC Type-Examination Certificate)**

No.	Type USL 05-Ex/ Type USL 05-LED-Ex	Part No.	Voltage	Built-in trans- former	Halogen lamp or LED illuminant		Ambient temperature range			
					Voltage	Socket	-20°C ≤ T _a ≤ +40°C		-20°C ≤ T _a ≤ +60°C	
1	(12 V) 5 W	3540.031.00	12 ≈	without	12 V/5 W	G4	2G T6	2D T80°C	2G T4	2D T130°C
2	(120 V/12 V) 5 W	3540.032.00	120 ~	with	12 V/5 W	G4	2G T6	2D T80°C	2G T4	2D T130°C
3	(230 V/12 V) 5 W	3540.033.00	230 ~	with	12 V/5 W	G4	2G T6	2D T80°C	2G T4	2D T130°C
4										
5	(12 V) 20 W	3540.035.00	12 ≈	without	12 V/20 W	G4	2G T4	2D T130°C	2G T3	2D T195°C
6	(24 V) 20 W	3540.037.00	24 ≈	without	24 V/20 W	G4	2G T4	2D T130°C	2G T3	2D T195°C
7										
8										
9	(230 V) 4 W-LED	3540.059.00	230 ≈	without	230 V/4 W-LED	GZ10	-	-	2G T6	2D T80°C

• **Order data:**

e. g. Lumistar luminaire USL 05-Ex, 12 V/20 W, Part No. 3540.035.00; with accessories: hinged bracket, Part No.: 0354.014.00 and claw spanner, Part No. 6816.001.00

• **Accessories:**

No.	Component	Part No.
1	Luminaire mounting, hinged bracket, stainless steel	0354.014.00
2	Luminaire mounting, flanged adapter collar, stainless steel	1356.010.00
3	Lumiglas timer module, Ex-timer switch, external, for timed light switching	on request
4	Claw spanner for screw-in lens, for opening the lamp	6816.001.00