

Sight Glass Fittings Rectangular

to be welded directly to tank

NORIS

Bauform 220

Application:

To show surface of a liquid, for insertion into attachments to tanks, vessels and silos.

Operating conditions:

Temperature : 243°C (Saturated steam or hot water in direct contact)
 Pressure: 16 bar

Option:

are available on request

Materials:

Welding pad	WN 1.4571	WN 1.4571	RSt 37-2
Cover	WN 1.4571	RSt 37-2	RSt 37-2
Screws	A4-70	8.8 vz	8.8 vz
Glass	Borosilicate glass DIN 7081, reflex		
Gaskets	Asbestos free (or other materials)		

Mounting instruction: After welding please examine if sealing area is plane. Otherwise re-machining is necessary.

Caution: Before putting the fitting into operation, the strength of the cutout reinforcement in combination with the vessel wall should be checked in accordance with TÜV leaflet B9 (AD Merkblatt B 9)

Example for an order:

Sight Glass Fitting Rectangular Bauform 220
 Welding pad WN 1.4571; Cover RSt 37-2
 370 x 70 mm

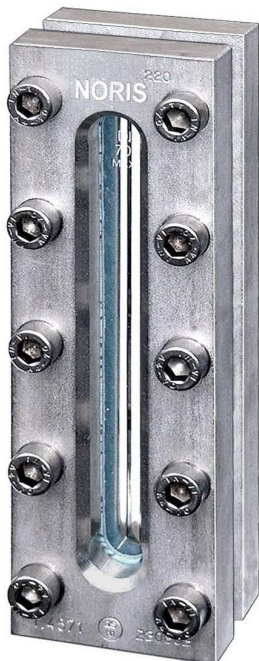

length 500-740



length 930

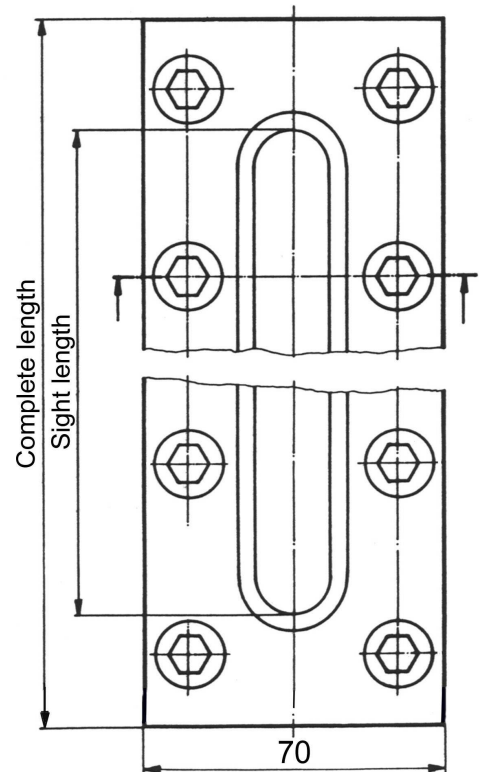
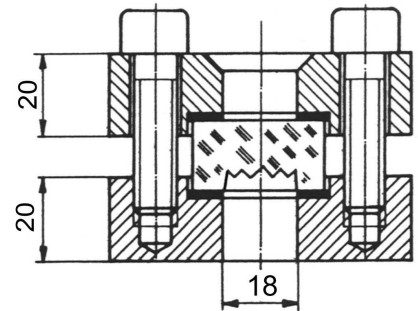

Dimensions:

Complete length*	170	220	250	310	370	500	620	740	930
Sight length	120	170	200	260	320	450	570	690	880
Sight interrupted						50	50	50	2 x 50
Number of screws	8	10	12	14	16	24	28	32	42

* By length 500 to 740mm there are 2 glasses / by length 930mm there are 3 glasses

Modification reserved



902 304 316
 quilinox@quilinox.com
 www.quilinox.com