

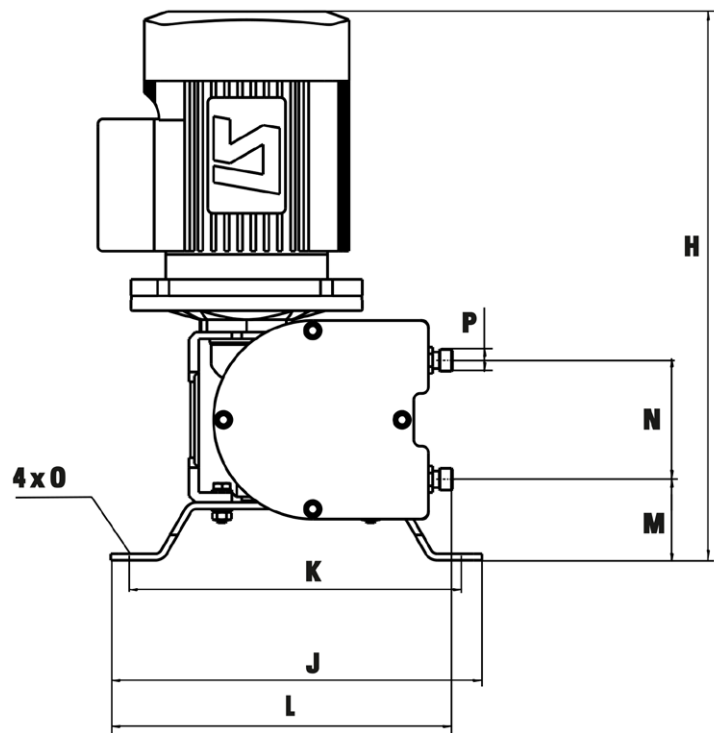

CAUDAL (L/H)

TEMPERATURA  
PRODUCTO (°C)

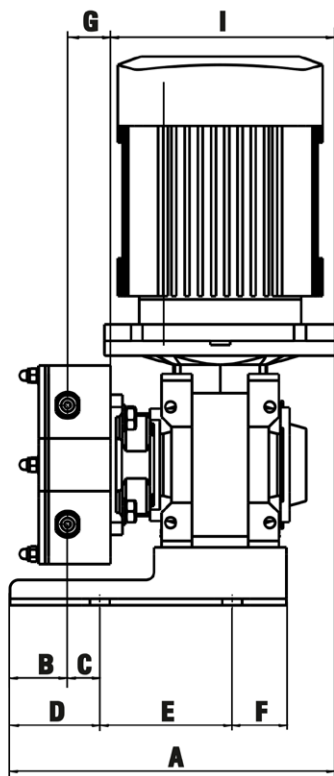
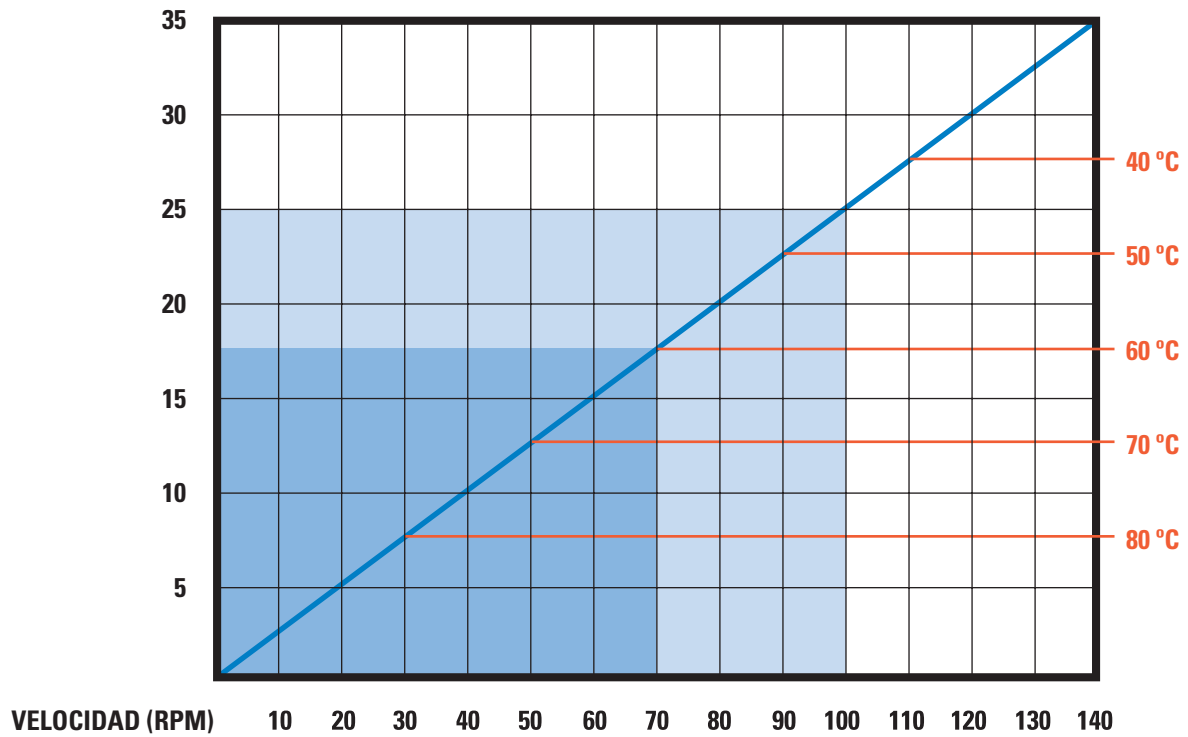

MODELO	A*	B	C	D	E	F	G	H	I*	J	K	L	M	N	O	P
T05	191,5	28,5	68	96,5	50	25	26	332	137	215	195	209	52	66	12	Espiga 5 mm

\* Pueden cambiar en función del accionamiento.