

Operating Range:

- Max viscosity 200cSt
- Max system pressure 16BAR
- Flow up to 140 m<sup>3</sup>/h
- Head up to 36m
- Temperature Range for PFA/PP from -5 to +80°C
- Temperature Range for PFA/PVDF from -35 to +100°C
- Electric motors from 1,5 to 18.5KW
- ATEX II - /3G cbk II C T5

Data for reference only. Parameters not associated



M PUMPS PROCESS s.r.l



## C MAG-PL

HORIZONTAL SEALLESS LINED  
CENTRIFUGAL MAGNETIC DRIVE PUMP,  
NO MECHANICAL SEAL

*The best solution for moving highly corrosive liquids, difficult to seal fluids and high purity*





# Pump Details

Epoxy primer and polyacrylic enamel water-based painting for the best chemical resistance against corrosion

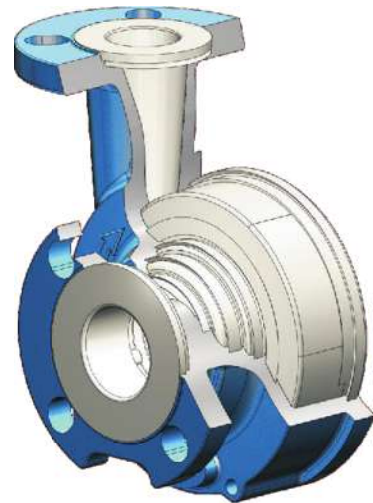

One single piece PFA front casing liner firmly anchored onto outer Ductile Iron shell to withstand piping loads, high system pressure and vacuum conditions. Transfer moulding technology assures constance of 5 mm thickness in PFA lining.

RWP QUICK CARTRIDGE KIT to guarantee an easy and fast maintenance, materials PP and PVDF.



Drain Plug for safe release of hazardous fluids or for flushing and monitoring.



O ring sealing system to avoid leakages to the atmosphere- different materials available:

- EPDM
- VITON®
- FEP

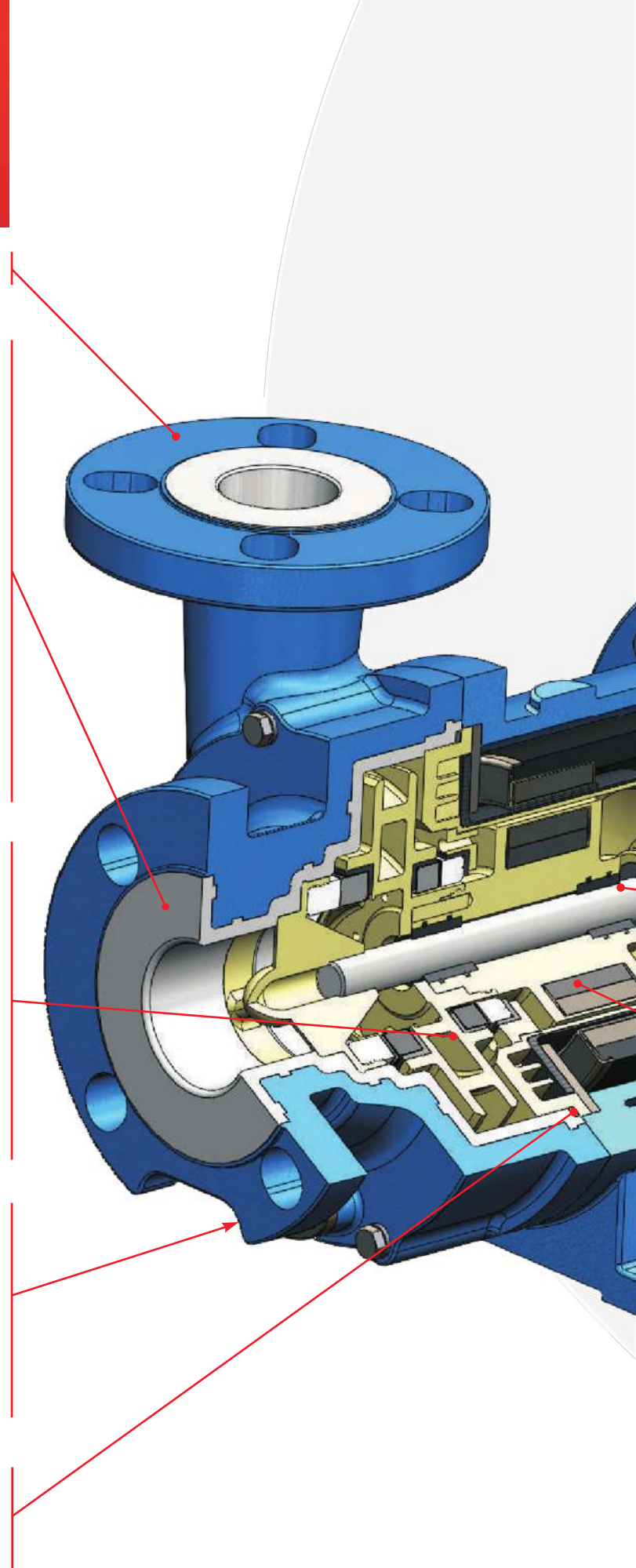

# Successful Installations



Transfer of Hydrofluoric Acid, Nitric Acid and Phosphoric Acid in a Germany based Fine Chemical Plant



C MAG-PL50 installed into Fiscal Sampling Systems for the oil and gas.

Bekaert China application for waste water transferring



C MAG-PL80 applied for truck unloading of H<sub>2</sub>SO<sub>4</sub> at 96% concentration



# Pump Codification

This configuration for complete unit only

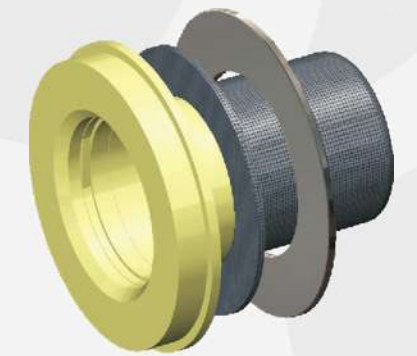
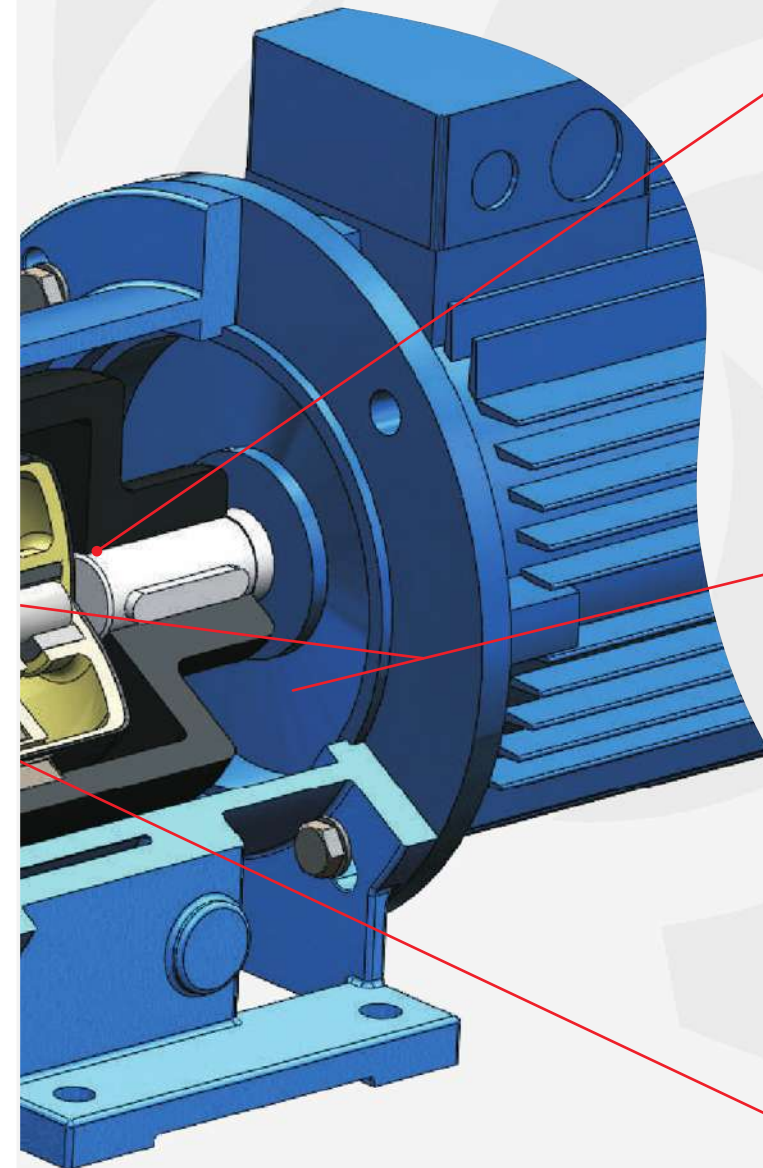
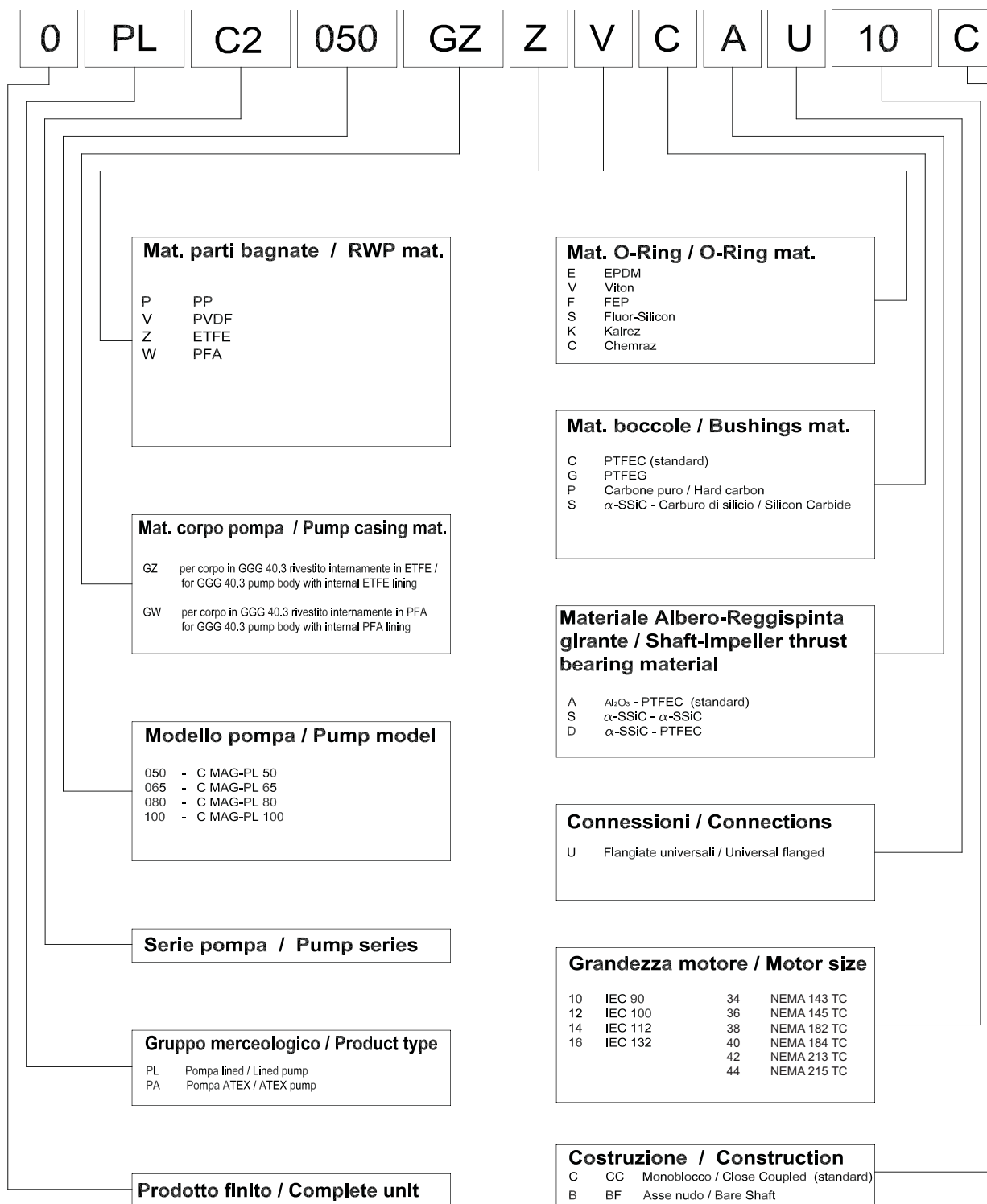

Double shell design with single piece primary shell made of thermoplastic materials, in PP GFR, PVDF CFR. Zero magnetic losses. No Eddy current lost, no waste of

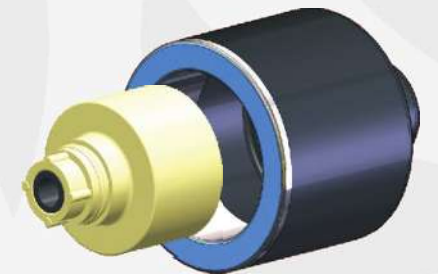

Totally encapsulated high power synchronous magnetic coupling with magnetic elements being mechanically locked. Insure the magnetic elements retain its position under unfavourable atmospheric conditions. Magnetic elements are dislodged on conventional glue system when operating in corrosive and high heat environment which



Shaft is firmly supported by front casing shaft support and rear casing support which design for handling high radial load and eradicate shaft deflection. Over size front and rear thrust bearings design for handling high axial load. Field assembling of the product lubricated bearing arrangement does not require special tools. The Shaft/ Bearing materials are available in three different configurations to provide the best solution each specific application:

- PTFEC – ALUMINA 99,7% (standard);
- CARBON – ALUMINA 99,7%,
- Silicon Carbide (SSIC)
- Silicon Carbide (SSIC).



## Application Fields:

- Fine Chemical Industry.
- Petrochemical Industry
- Semi-Conductor Industry
- Power Plant
- Pulp and Paper Industry
- Recycling Industry - Plating Industry

- Chemical Industry
- PCB Industry
- Waster Water Industry
- Pharmaceutical Industry
- Galvanizing Industry
- Plating Industry

# Pump Performances

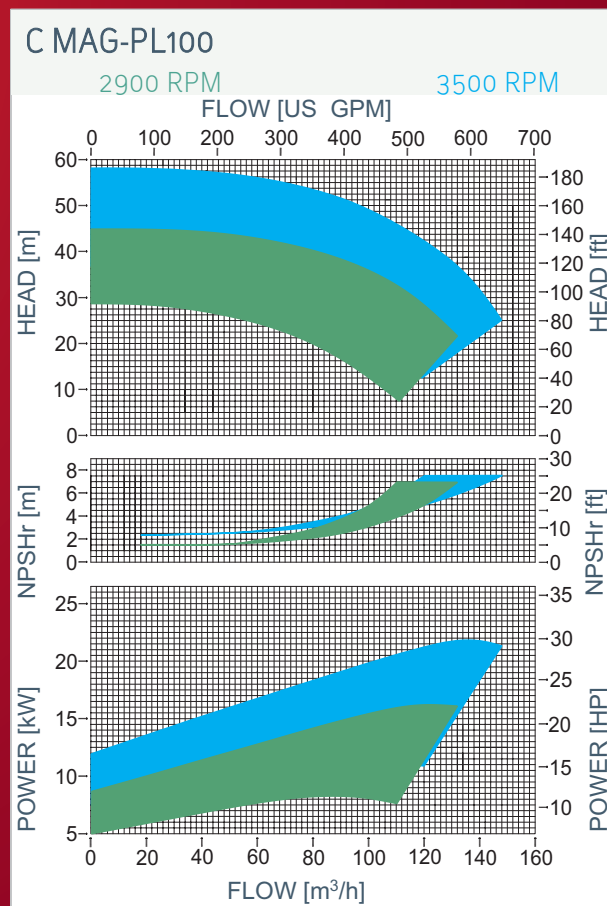
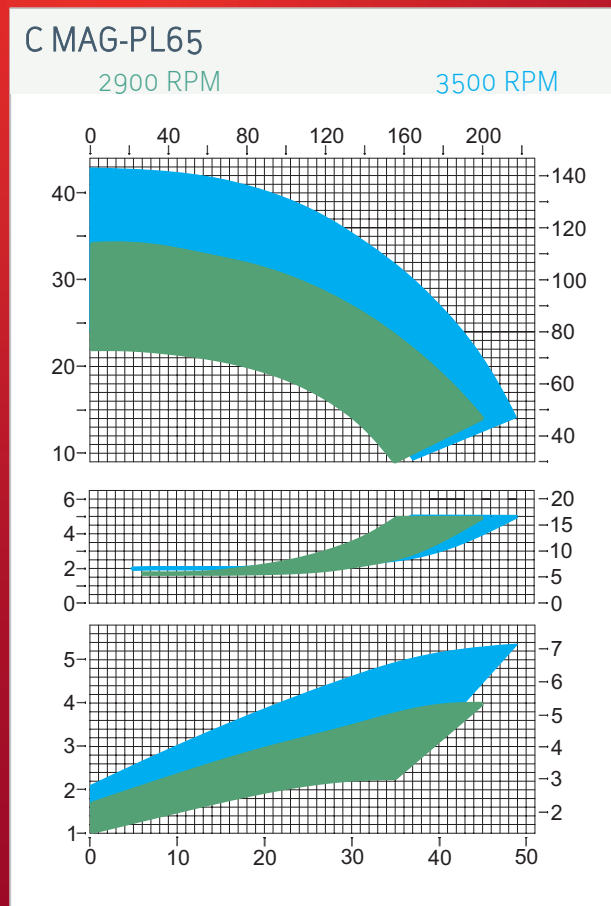
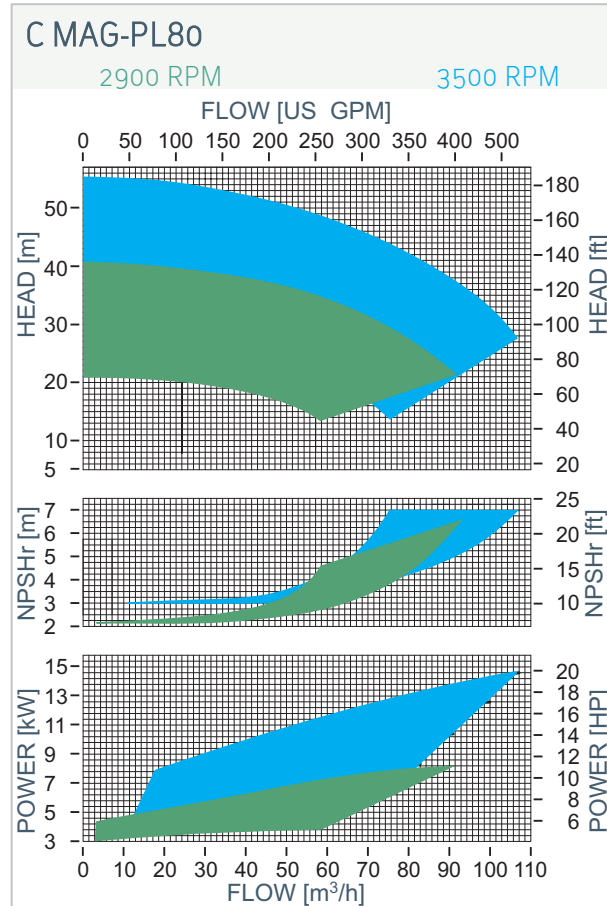
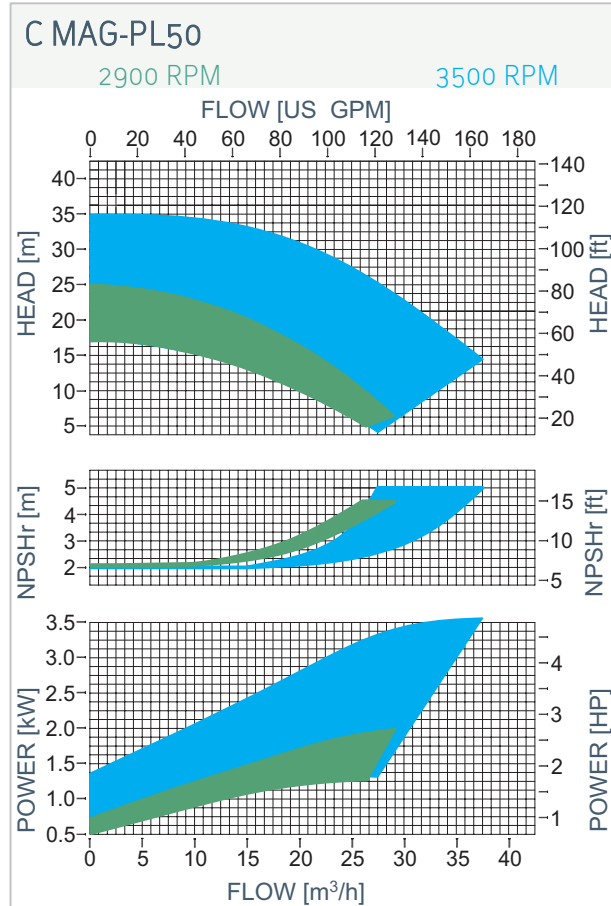

# Guideline for C MAG-PL Pumps series

## Dry running capability

- STD Version (PTFE-Alumina) Up to 5 min. NOT FREQUENTLY
- SPECIAL DRY RUNNING Version (Carbon-Sic) Up to 1 hour
- SPECIAL FOR SOLID Version (Full Sic) Up to 1 min. NOT FREQUENTLY If diamond coating Up to 30 min (on request).

## Solid handling capability

- STD Version (PTFE-Alumina) Solids up to 3%, particles up to 2 mm.
- HYDRAULIC BARRIER Version Solids up to 30%, particles up to 3\* mm.

\*Depend on each application, please contact M PUMPS



# Dry Running Capability Chart

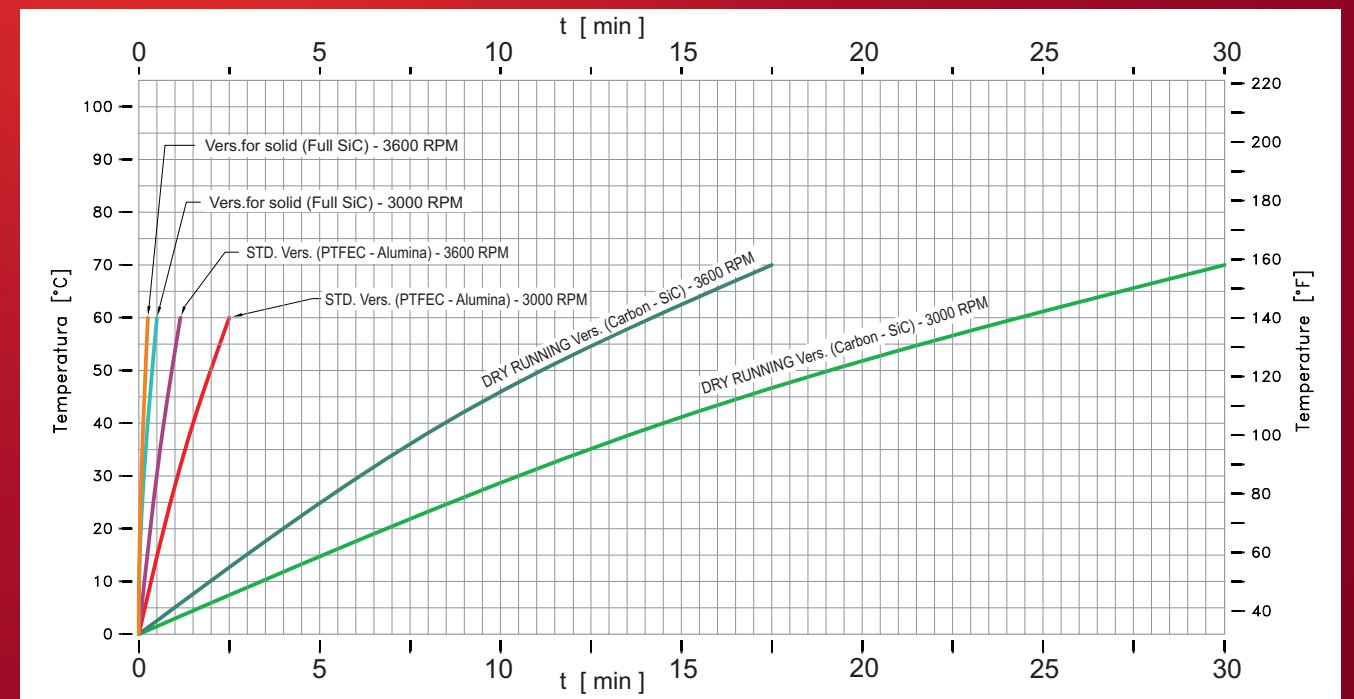

Note: The present chart is referred to Dry running with residual liquid into the pump.

# Temperature Limits

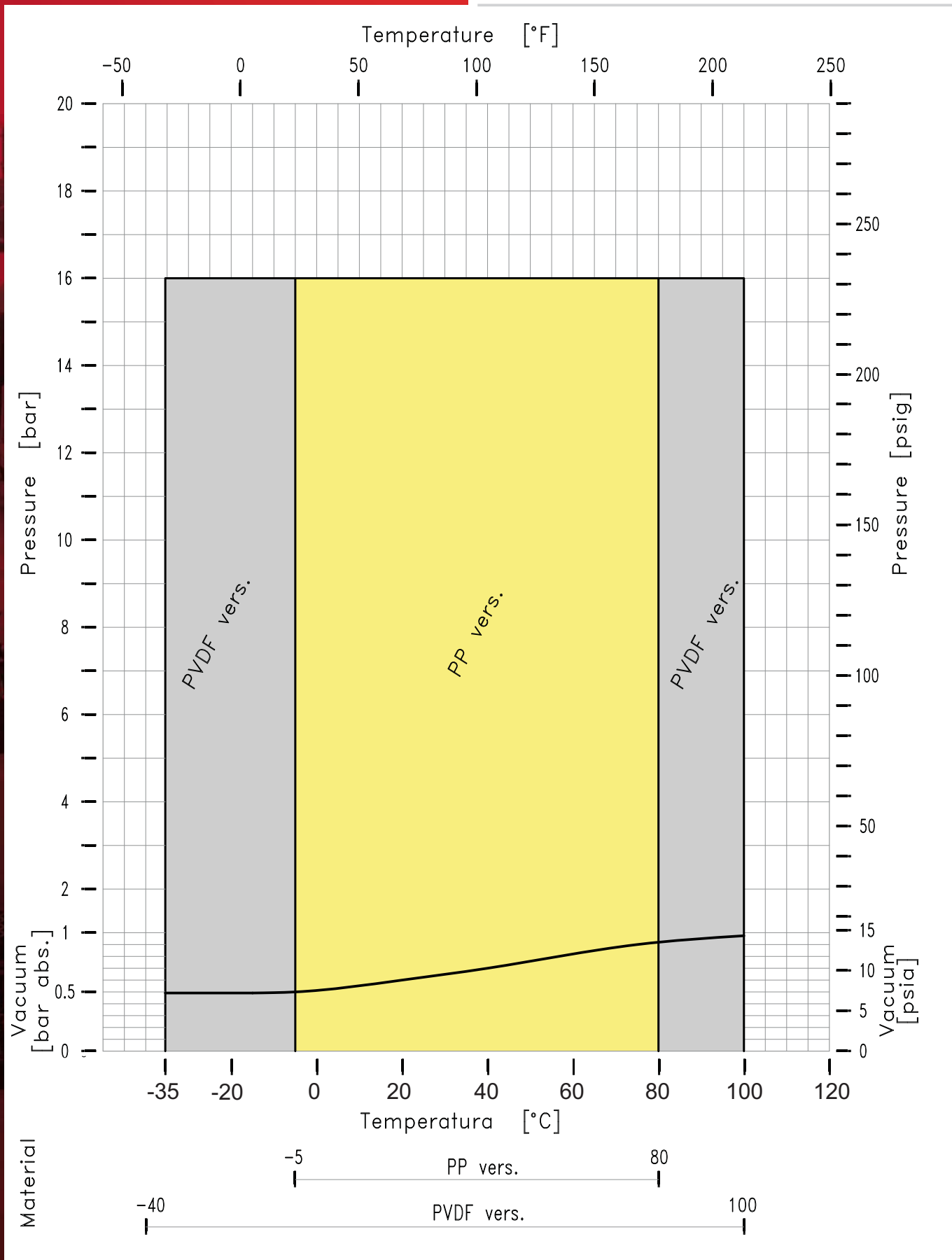

# Outline dimensions

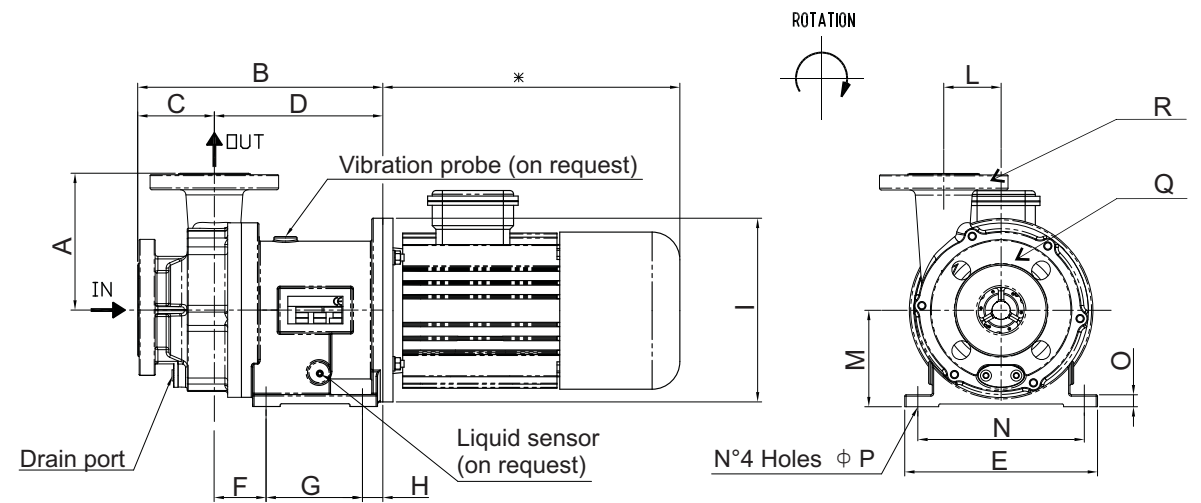

## 2 Poles motor

Pump Model	Motor size [IEC]	Motor power [kW]	A	B	C	D	E	F	G	H	I	L	M	N	O	P	Q		R		Pump Kg less motor	Baseplate Kg	Motor Kg **
																	PN 16	ANSI 150#	PN 16	ANSI 150#			
C MAG-PL 50	90	2.2	267	84	184	210	57	106	21	200	62.5	105	135	180	13	11	50	2"	40	1" 1/2	23.5	22.5	53
	100 / 112	3 / 5.5	149																				
C MAG-PL 65	100 / 112	3 / 5.5	321	103	218	250	80	100	38	250	73	135	210	15	14	65	3"	50	2"	37	27	70	
	132	7.5	172																				341
C MAG-PL 80	132	7.5	198	368	121	247	250	89	120	38	300	82	153	210	15	14	80	4"	65	3"	46	34	106
C MAG-PL 100	160	18.5	227	409	129	280	290	93	150	38	350	102	180	250	20	14	100	4"	80	3"	56	51	173

\*: depend on the motor manufacturer  
 \*\*: for reference only

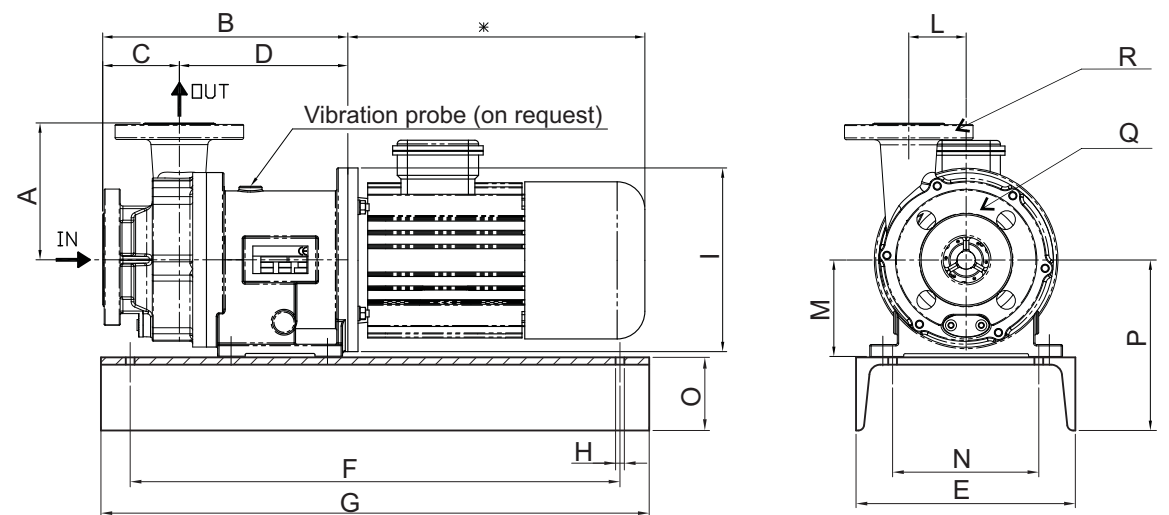



# Design and Features

- 1) Single stage, PFA lined , PP / PVDF wetted parts, in-between supported closed impeller, magnetic drive centrifugal pump.
- 2) Transfer moulding technology assures homogeneity of 5mm thickness in PFA lining that offers superb permeation resistance.
- 3) Vacuum Proof by unique technique of anchoring PFA lining onto the pump casing.
- 4) One piece solid machined impeller with no metal insert.
- 5) Module designed allows quick changing of parts and minimum stock.
- 6) Separate Impeller and internal magnet allows individual component replacement.
- 7) Closed coupled version reduces installation cost, , small footprint requirements.

## How to protect your pump



### Emotron M20

- It detects process inefficiency. Early warnings allow you to take preventive action.
- It protects pumps and other equipment against damage
- It measure shaft power output and uses the motor as a sensor.
- The result is reduced maintenance and installation costs, extended equipment lifetime and increased reliability.

### Technical data

- Supply voltage 100-240 VAC / 380-500 VAC / 525-690 VAC
- Frequency 50 Hz / 60 Hz
- Rated current Up to 999 A via current transformer
- Protection class IP20
- Approvals CE, UL, cUL

