

HORIZONTAL, SEALLESS CENTRIFUGAL PUMP WITH PERMANENT MAGNET DRIVE SYSTEM NO MECHANICAL SEAL



CM MAG-M Series

The separation of liquid chamber/atmosphere by means of an isolation shell is the best solution to pump aggressive, explosive and toxic liquids, hydrocarbons, heat transfer liquids and liquids difficult to seal.

The hermetic sealless is the most convenient and safety solution for kind of industries.

A wide range of pumps covers the different performances.

Low flow and high heads are the main characteristics of this pump design.

CM MAG-M

PUMP DETAILS



Field assembling of the product lubricated bearing arrangement does not require special tools.
The bearing materials are available in different materials to provide the best solution for each application: Silicon Carbide (SSIC), Tungsten Carbide (WC), Carbon to allow accidental dry running transitory and PTFEC/G or PEEK compound (for any applications where the Carbon cannot be used.)
The use of elastic rings reduces the sleeve bearing loads and the thrust bearing loads to the minimum, to guarantee many years of maintenance-free operation.

CF8M Pump Casing & Impeller high quality casting components.
Other materials:
- Hastelloy[®] C276,
- Incoloy[®] 825,
- Duplex,
- Others materials available on request.



RWP QUICK CHANGE CARTRIDGE KIT to guarantee an easy and fast maintenance.

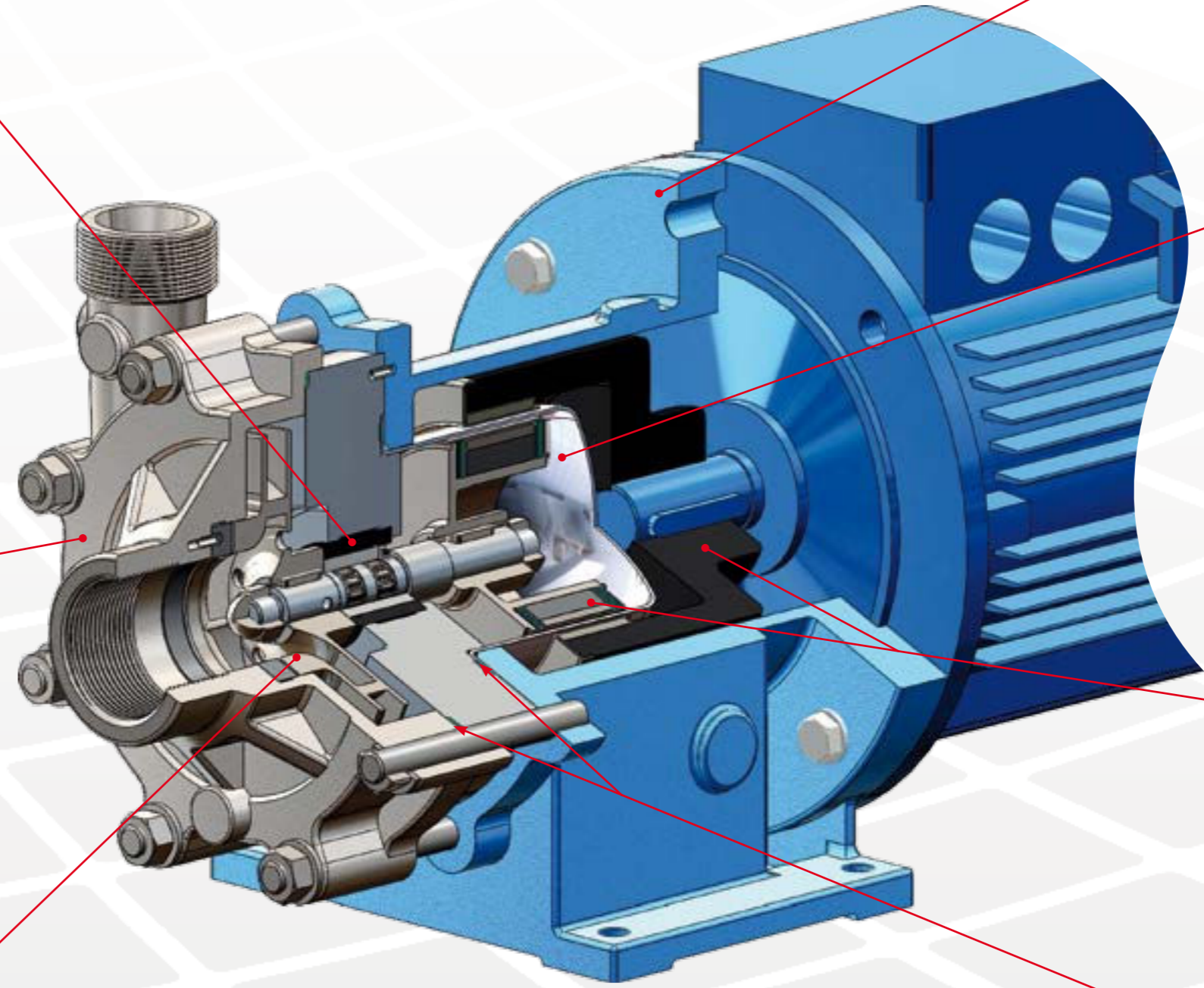

Epoxy primer and polyacrylic enamel water-based painting for the best quality resistance linked to the environmental respect.



The rear shell is made of one single piece, no welding, ellipsoidal profile that has been studied to withstand higher pressures than the traditional one.
AISI 316 is the standard construction, Hastelloy[®] C276 and titanium alloy upgrade when higher pressure ratings and increased efficiency are required.

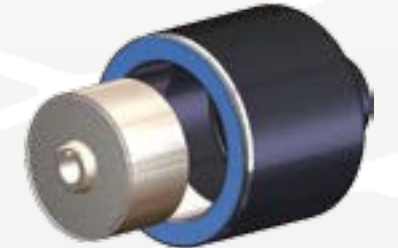

High power synchronous magnetic coupling designed by our Technical Office and with rare earth magnetic elements mechanically locked.
The high performance magnets can operate at liquid temperatures of up to 662°F (350 °C) without external cooling.

The sealing system with flat gaskets prevents from leaking in the atmosphere – different materials available:
- Asbestos free (standard)
- PTFE/R
- Graphoil[®]
- GYLON[®]
- Other on request

Pump construction

Close-coupled drivers are conventional drivers mounted directly to pumps frame. No base, coupling or guards are required for this mounting style.

Connections:

Universal flanges rating according to DIN Norms Class PN16 - 40 & ANSI B16.5 Class 150 (standard)

Threaded BSP (GAS) & NPT (available on request)

Other on request

Performance curves

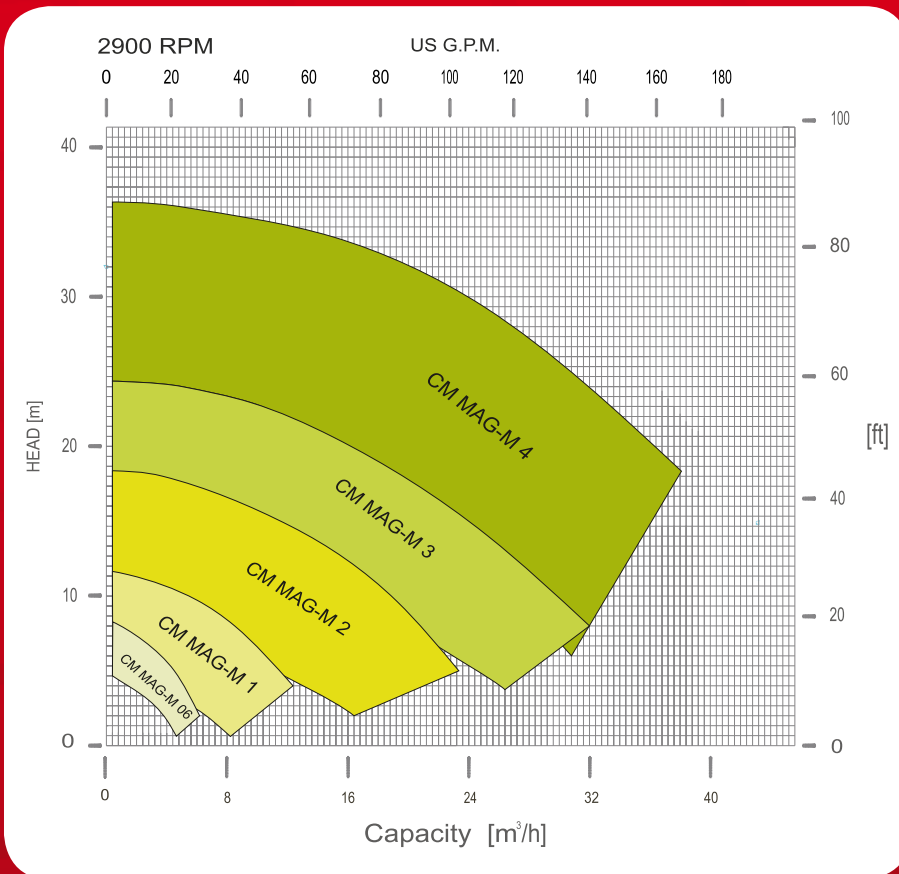

Operating Limits

- Max viscosity: 200 cSt
- Max system pressure: 25bar (standard)
- Higher pressure version available on request.
- Flow up: to 35 mc/h
- Head up: to 36m
- Temperature range: from -185 °F (-120 °C) to +662 °F (+350 °C)
- Electric motors: from 0,25kW up to 11 kW
- Available ATEX II - / 2G cbk II C T2 - T5

Manufactured by:



A unit of
Mischiatti
GROUP

For more information please contact:

