

ZEROCON TIGHT AS A WELD SEAM

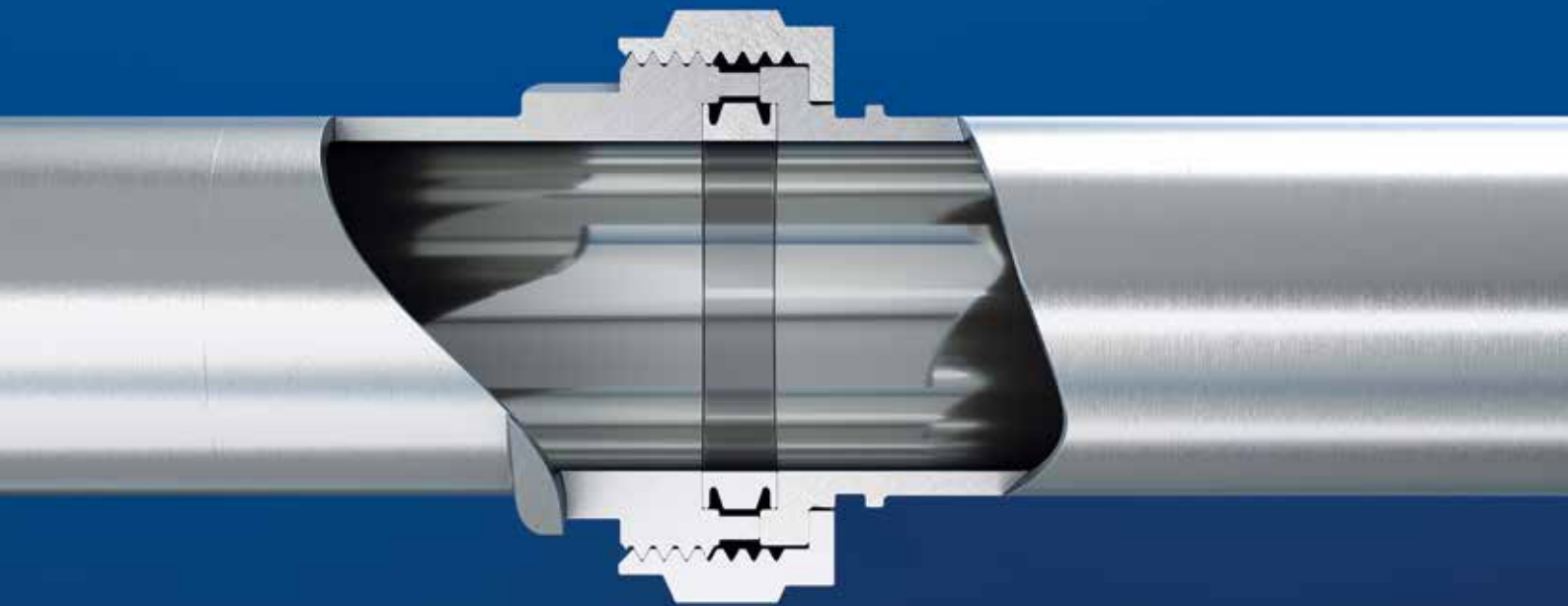

The unique detachable connection with the tightness of a weld seam

ZeroCon is the new, patented, 100% stainless steel connection system for safe and rapid connection of tube systems. With ZeroCon you make zero compromises!

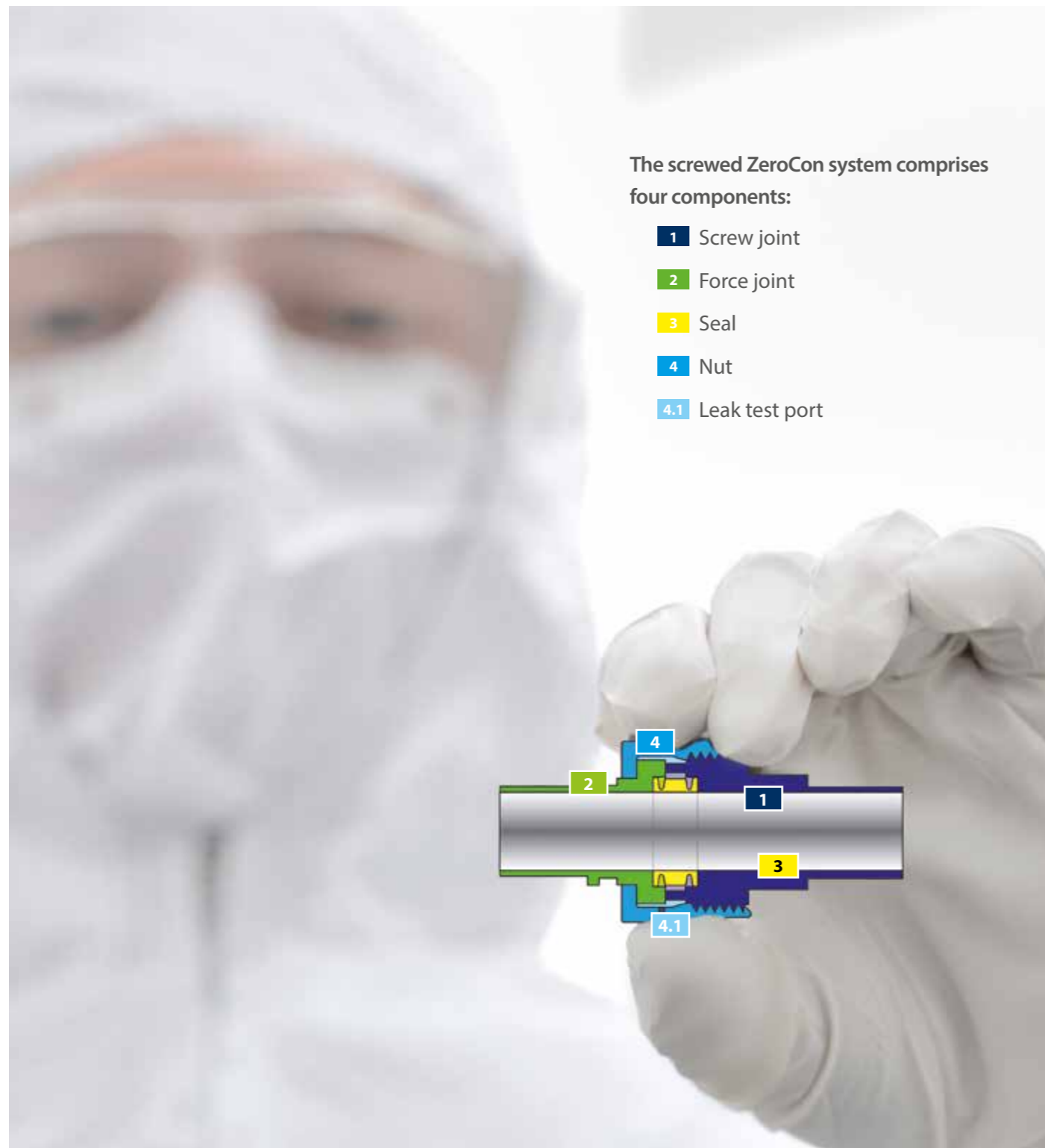

The screwed ZeroCon system comprises four components:

- 1** Screw joint
- 2** Force joint
- 3** Seal
- 4** Nut
- 4.1** Leak test port

ZeroCon as screwed and flanged version: Two designs following the same principle



	ZeroCon - screwed version:	ZeroCon - flanged version:
Imperial:	1/4" to 1" (6.35 mm up to 25.40 mm)	1" to 4" (25.40 mm up to 101.60 mm)
ISO and Metric:	on request	on request

The advantages at a glance:

Completely leakproof (A)

Because the same material is used throughout, the connection is as tight as a weld seam (helium leak rate $\leq 10^{-10}$ mbar l/s)

No dead space (B) and perfect pharmaceutical barrier (C)

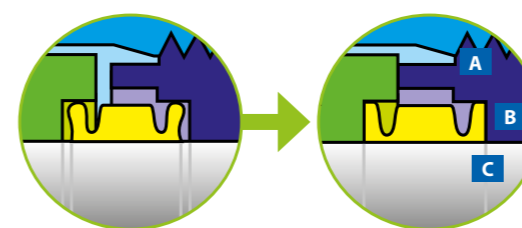

The seal ring adapts to fit perfectly when pressed in, ensuring complete sealing and no dead space

Robust connection

Suitable for applications involving high-pressure, critical vacuum and extreme temperature conditions

Dynamic stress resistance

Anti-twist locking and outward precision fit prevent negative impact of external forces and torques

Temperature stable

From - 196 °C (-320.8 °F) to +350 °C (+662°F)

Pressure stable

Screwed version up to 440 bar (6381.66 psi)
Flanged version up to 150 bar (2175.57 psi)

No flow disturbances

Highest surface quality
Ra $\leq 0.4 \mu\text{m}$ (15 μinch), electropolished $\leq 0.25 \mu\text{m}$ (10 μinch)

No outgassing of material

1.4435 / UNS S31603 (316L)

Easy installation

Self-centering, end stop and integrated leak test port

Maintenance-free

No seal replacement required unlike with soft seals

Efficient, long-lasting and reliable: ZeroCon Connection

ZeroCon is the simple and efficient solution if you want a new, built-to-last connection. It combines all the advantages of a detachable connection with those of a welded connection. For this reason, ZeroCon can also be used in all areas of application and industries and is suitable for all applications. Try it for yourself and see.

The modular design of the ZeroCon connection means that there is nothing to stop you adding to or adapting the system at a later point. System maintenance and connection with further systems can be carried out rapidly, easily and cost efficient.



The flexible solution for everyone who refuses to compromise on safety: ZeroCon

Advantages of the ZeroCon connection

	Micro-electronics	Life Science	New Energy
Unique product design			
- Self-centering due to interlocking design	■	■	■
- No risk of damage from excessive tightening torques	■	■	■
- Easy, unproblematic connection with further pipelines	■	■	■
- Easy to switch to other sizes	■	■	■
- External forces and/or torques do not affect the connection	■		■
- Turbulence-free		■	
- Quick and easy to install and remove	■	■	■
- Clearly arranged, simplified product range (seal)	■	■	■
- No impairment of flow		■	
Sustainability and efficiency			
- Easy, rapid leak testing via test port	■		
- Frequent reusability of flange and nut	■	■	■
- Maintenance-free	■	■	■
- Briefer flushing times	■	■	■
Extreme and high purity applications			
- Much more resistant to aggressive media than soft seals	■	■	■
- Also suitable for high pressure systems up to 440 bar / screwed version (6381.66 psi)	■		
- Temperature-stable from -196 °C (-320.8 °F) up to +350 °C (+662°F)	■	■	■
- Also sterilizable with superheated steam	■	■	■
- Use in ultra-high vacuum applications	■		
- 100% sterilizable, no deposits, films of bacteria or cultures		■	■
- Meets the highest purity standards	■	■	■
Safety			
- As tight as a weld seam	■		
- No contamination of the medium from the outside	■		■
- No loss of media/leakage of toxic media to the environment	■		■
- No outgassing of material that can contaminate the process medium	■	■	■
- No cavities for medium to collect in	■	■	■
- No detachment of coatings possible (no possibility of contamination of medium)	■		■

ZeroCon and manifold systems

The perfect combination by Dockweiler

The use of prefabricated components is becoming more and more important in the installation of stainless steel piping systems. Modular construction increases efficiency, with connection components playing a key role.



The ZeroCon connection was developed to combine the safety of conventional weld seams with high ease of use. It provides a reliable and tight connection that can withstand demanding operating conditions.

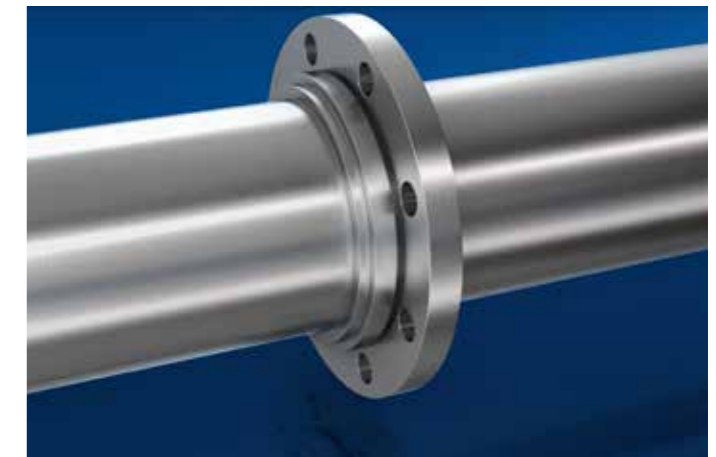
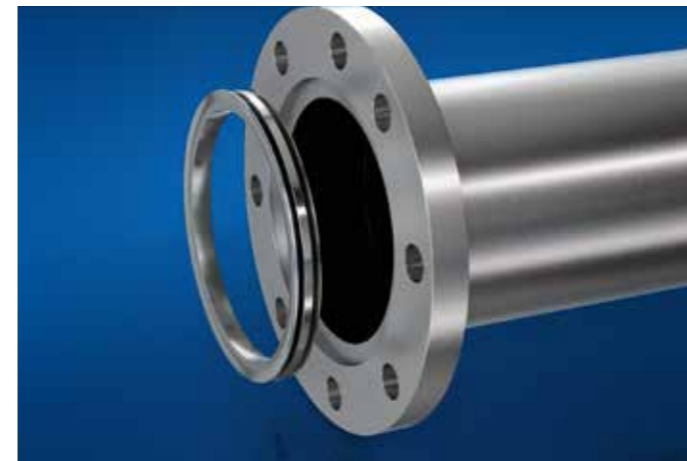

The design of the ZeroCon allows for quick and easy assembly, reducing installation time and costs. This unique connection is available in two versions: a bolted version (1/4-1 inch) and a flanged version (1-4 inch).

