

Pigging system



Pigging systems
adapted to
your **manufacturing processes**



*The expertise
of a designer
and manufacturer*



QUILINOX[®]
ALL ABOUT FLUIDS

PIGGING OBJECTIVES

Pigging involves propelling a pig through a pipeline to recover residual product, optimizing yield and reducing losses. The ABSCISSE pigging system enhances process efficiency while ensuring optimal hygiene.

✓ Increase your yields with the ABSCISSE pigging system €

Optimize your **performance** by recovering up to **99%** of residual product volumes from your production lines..

For example :

- For a DN80 pipeline: a residual volume of 5 liters per meter
- For a DN100 pipeline: a residual volume of 8 liters per meter

These volumes, often underestimated, can be recovered and commercially valorized through pigging.

✓ Production line optimization and maximum flexibility ↗

To innovate and diversify their product ranges, manufacturers must **optimize** their production lines.

The ABSCISSE pigging system allows the use of **a single line for multiple products**, reducing the need for dedicated pipelines while increasing flexibility and capacity.

✓ Enhanced traceability 🔍

The ABSCISSE pigging system ensures a high recovery rate, **reducing the risk of cross-contamination**.

During transitions, it minimizes mixing and dilution, preserving the **quality** of finished products. This optimized process ensures precise **traceability** at every stage of production.

✓ A positive environmental impact ♻️

Respect for the environment is both an **ethical commitment** and a key criterion for consumers. Pigging helps reduce waste-related costs while **lowering the carbon footprint**.

By **reducing losses** and **saving** water, energy, and chemicals, it provides a fast return on investment.

OUR MARKETS

Specific solutions tailored to the requirements and constraints of each market.

THE FOOD INDUSTRY

PERNOD RICARD, ROEDERER, YOPLAIT, AGRANA, BARRY CALLEBAUT, CASTEL FRERES, CD FOODS, CEMOI, COCA COLA, DANONE, GEORGES MONIN, GH MUMM, GIDA CONFISERIES, GYMA, LA BOULANGÈRE, LACTINOV, LA MARTINIQUAISE, LA NORMANDISE, LESIEUR, MARTELL & CO, NUTRISSET, PASQUIER ...

THE COSMETICS INDUSTRY

L'OREAL, PERFUMIA GAL, SUPERGA BEAUTY, BCM COSMÉTIQUE, COLGATE, COSMEVA, FAREVA, FARMACLAIR, FIABILA, FIRMENICH, FRAGRANCE PRODUCTION, GEMEY MAYBELLINE, GILLETTE, HENKEL, LABORATOIRES GALDERMA, LABORATOIRES SARBEC ...

THE CHEMICAL AND PETROCHEMICAL INDUSTRY

PPG COATING, PROCTER & GAMBLE, SYNGENTA, TOTAL, AKZO NOBEL, ARKEMA, CONDAT, CROMOLOGY, ESTENER, FLUKAR, HAFA, LBC SOGESTROL, LUBRIZOL, MINERVA, MOTUL, MULTISOL, ORLEN ...

THE PHARMACEUTICAL INDUSTRY

SANOFI, CHRISTEYNS, FARMACLAIR, JOHNSON & JOHNSON...



ABSCISSE

FROM DESIGN TO MANUFACTURING



Cost optimization, quality control, and environmental standards are at the heart of our priorities. ABSCISSE provides solutions that reduce effluents, ensure optimal line cleaning, secure processes, and enhance production line versatility.

Since 1994, ABSCISSE has been designing and manufacturing complete systems and equipment for fluids (liquids and viscous substances) in the following fields :

- ✓ Pigging system
- ✓ Sampling
- ✓ Filtration
- ✓ Tank breathing and protection

Industry-specific expertise

Our experienced team provides effective solutions for the chemical, petrochemical, food, cosmetics, pharmaceutical, and biotechnology industries. ABSCISSE manages its entire production process, offering customized equipment tailored to the specific needs of its clients.

Reliability and traceability

Thanks to an advanced ERP system, a network of validated European subcontractors, and a quality assurance system, ABSCISSE ensures the traceability and compatibility of its products with your applications. We place cost reduction, quality control, and compliance with environmental standards at the heart of our priorities.

An international presence

A key player in France and Europe, ABSCISSE is expanding its international presence across all five continents.

OUR APPROACH

A CUSTOMIZED APPROACH, TAILORED TO YOUR INDUSTRIAL PROCESSES.

Because we design and manufacture our equipment in-house, we ensure **complete control** over the entire process, **from design to commissioning**.

A trusted relationship: attentive listening to your needs to offer **configurable** solutions.

Drafting of your specifications

Together, we develop your specifications, tailored to your industrial process, to provide an optimized solution ensuring a fast return on investment.

Development of your PFD

We support you in creating your PFD (Process Flow Diagram), a key element for visualizing the pigging process and defining the optimal solution.

AB6 Design

Our in-house design office customizes each pigging system to meet the specific constraints of every installation.

AB6 Manufacturing

Our production facility includes machining, welding, and metalworking workshops, ensuring full control over the manufacturing process.

On-site commissioning

We ensure the on-site commissioning of our pigging systems and train your operators in their use and maintenance for effective and autonomous operation.

With ABSCISSE, every solution is designed to combine flexibility, innovation, and performance.

Because every process is unique, our solutions adapt to your needs!

THE PIGGING PROCESS



Single pig solution : Transfer to a destination
Manual or Automatic Version.

- + Single destination
- + Easy integration on new or existing piping
- + Cost-effective solution

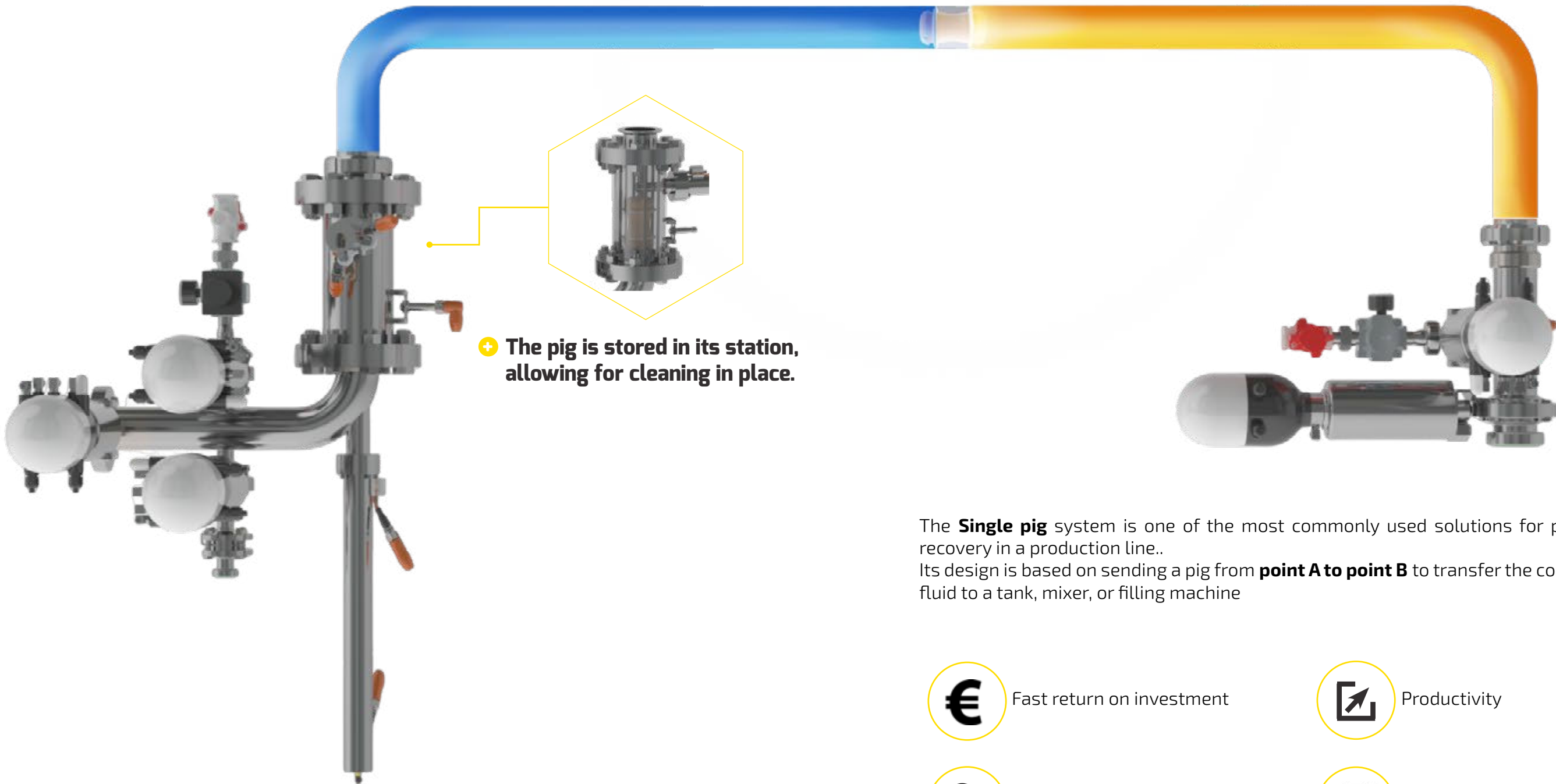

+ The pig is stored in its station, allowing for cleaning in place.

The **Single pig** system is one of the most commonly used solutions for product recovery in a production line.. Its design is based on sending a pig from **point A to point B** to transfer the conveyed fluid to a tank, mixer, or filling machine



Fast return on investment



Productivity



Reliability



Sustainable solution

Pigging System

THE PIGGING PROCESS

Dual pig solution : Multi-distribution Automatic version.

- + Multi-distribution
- + Increased flexibility
- + Fast return on investment

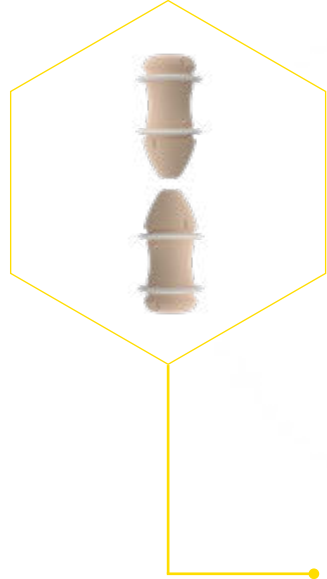

The **Dual pig** allows fluid pigging towards multiple destination points, providing a flexible solution. It is particularly suitable for multi-product lines, where different types of fluids share the same piping system.



Fast return on investment



Productivity



Reliability



Sustainable solution

LAUNCHING STATIONS/ RECEIVING STATIONS

On its entire range, ABSCISSE offers manual, semi-automatic, or fully automated solutions.



CLEAN-IN-PLACE SOLUTION

Concentric Inline Station

For viscosity < 10 000 cpo
Marker-free

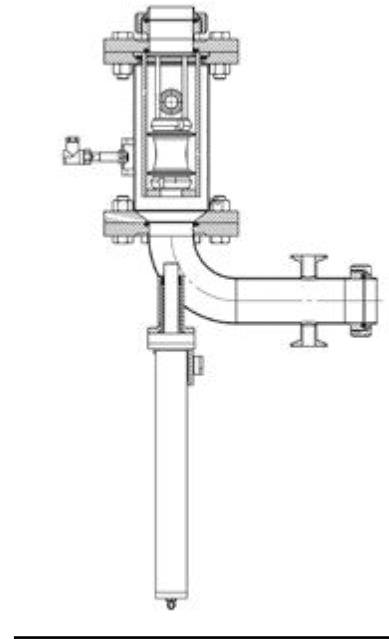
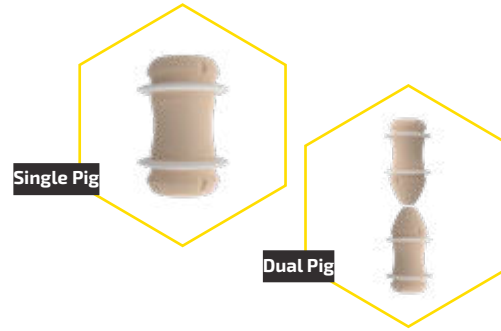

CLEAN-IN-PLACE SOLUTION

Eccentric Inline Station

For viscosity > 10 000 cpo
With or without markers

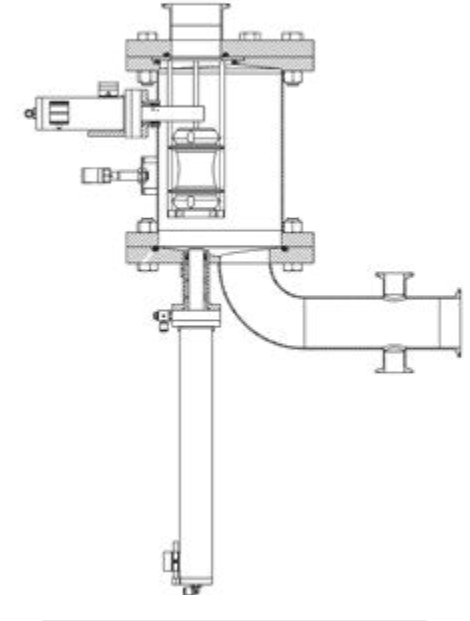

COST-EFFECTIVE SOLUTION

T-station

A cost-effective solution particularly suited for fluids without bacteriological risk

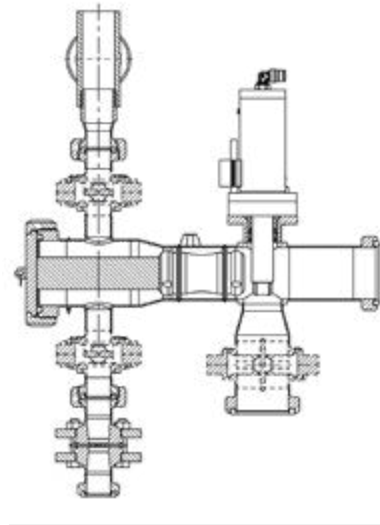

RECEIVING STATION

Receiving station

It ensures the safe reception and extraction of the pig at the end of its course or enables its return to the starting station in an automated version.

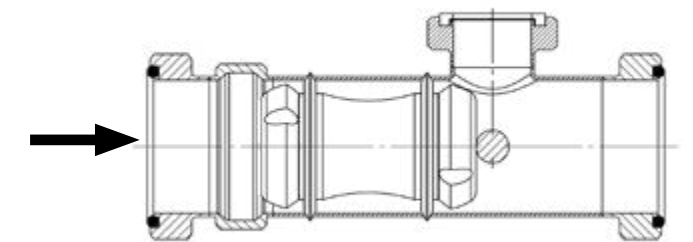

MULTIPLE DISTRIBUTION

Our Single Pig and Dual Pig pigging systems can be complemented with 3-Way valves or intermediate stations, allowing pigging towards multiple destinations..



SINGLE PIG SOLUTION

Piggable 3-way valve
For multiple fluid distribution

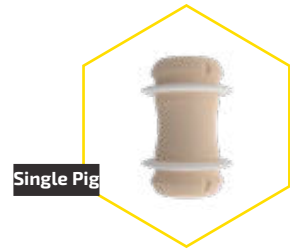

DUAL PIG SOLUTION

Intermediate Station
For multiple fluid distribution

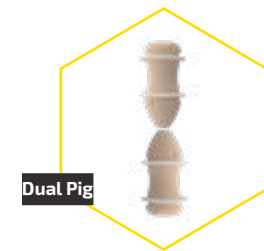

3-Way L-Port Valve

3-Way T-Port Valve

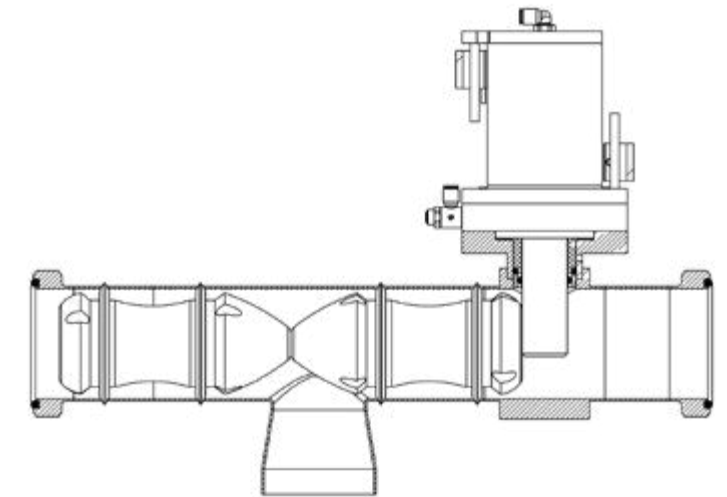
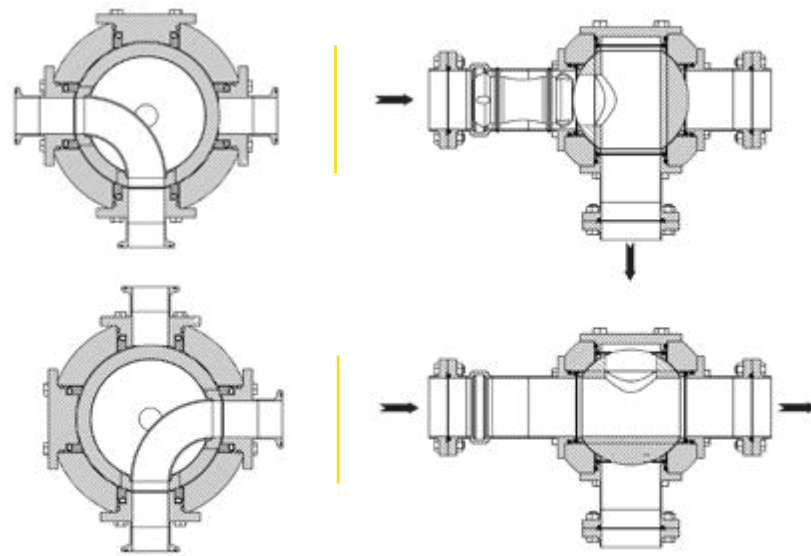

+ Key Benefits

Multi-distribution : Enables fluid transfer and pigging to multiple destinations (tanks, packaging lines, etc.) without product loss.

Increased Flexibility : With intermediate stations and 3-way valves, a single circuit can handle different fluids, simplifying operations and reducing downtime.

Fast Return on Investment : Ensures smooth and quick transitions between productions, minimizing interruptions and optimizing production line efficiency.

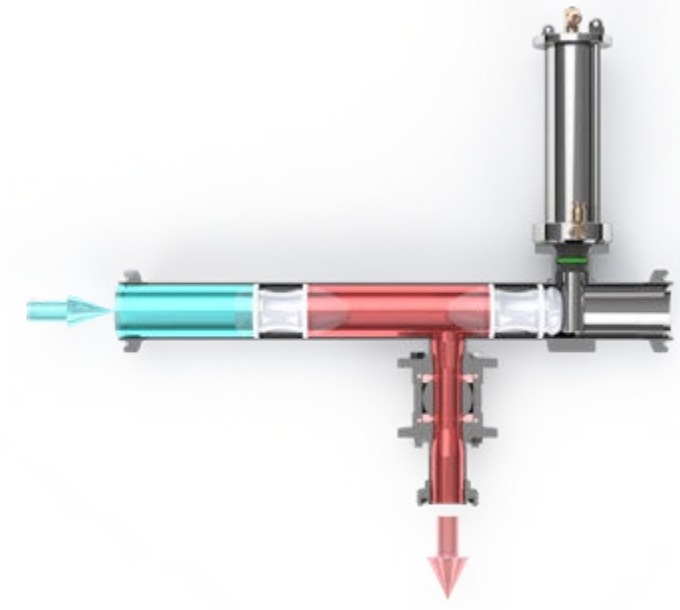

Data provided for information purposes. Subject to change.



Pigging System

ABSCISSE PIGS



A high-performance pig

Our pig, consisting of a rigid three-part body (central body and ends) and two profiled elastomer lips, ensures precise and efficient cleaning, even in short-radius bends (1.5D).

Encapsulated magnets for reliable detection

The combination of the rigid body and encapsulated magnets prevents any detachment and ensures a constant magnetic field. Coated in epoxy and neutral to process fluids, the «bar» type magnets provide optimal detection.

Flexible lips for effective cleaning

The two profiled elastomer lips ensure the pig's sealing. This specially designed profile, featuring a leading edge, enables effective mechanical pigging of the pipeline.

Key Benefits

- ✓ Low push pressure required for pig movement.
- ✓ Reduced maintenance costs: Only the lips are considered wear parts.
- ✓ Recovery of up to 99% of residual product volume.

TECHNICAL DATA

Design	Single Pig, Dual Pig, Opposite
Body & extremities	Polypropylene, PEEK, Polyamide
Lips	SILICONE, EPDM, FKM, HNBR*, FFKM* ...
Standards	SMS, DIN, OD, ISO, SCHEDULE
Diameters	From DN38 to DN300
Certifications	FDA, CE1935/2004, BNIC*, Phtalates free*, Bisphénol A et S free*

* On request

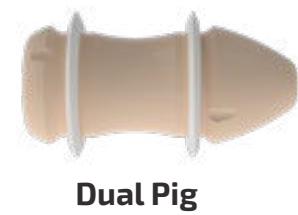

An international presence



A range of complementary products



SAMPLING



FILTRATION



BREATHING VALVES



QUILINOX[®]
ALL ABOUT FLUIDS